

Fragments of geometric topology from the sixties

SANDRO BUONCRISTIANO

Contents

Preface	(iii)
Acknowledgements and notes	(iv)
Part I – PL Topology	
1. Introduction	1
2. Problems, conjectures, classical results	5
3. Polyhedra and categories of topological manifolds	13
4. The uniqueness of the PL structure of \mathbb{R}^m ; the Poincaré Conjecture	21
Part II – Microbundles	
1. Semisimplicial sets	41
2. Topological microbundles and PL microbundles	53
3. The classifying spaces BPL_n and $BTop_n$	61
4. PL structures on topological microbundles	72
Part III – The differential	
1. Submersions	77
2. The space of PL structures on a topological manifold	88
3. The relation between $PL(M)$ and $PL(TM)$	91
4. Proof of the classification theorem	93
5. The classification of the PL structures on a topological manifold M ; relative versions	104
Part IV – Triangulations	
1. Immersion theory	
2. The handle-straightening problem	
3. Homotopy tori and the surgical computation of Wall, Hsiang, and Shaneson	
4. Straightening handles of index zero	
5. Straightening handles of index k	
6. Groups of automorphisms of a manifold	
7. The homotopy type of Top_m/PL_m	
8. The structure of the space of triangulations	
9. Stable homeomorphisms and the annulus conjecture	

Part V – Smoothings

1. The smoothing of a PL manifold
2. Concordance and isotopy
3. The classifications of smoothings by means of microbundles
4. Semisimplicial groups associated to smoothing
5. The structure theorem for smoothings
6. The triangulation of a differentiable manifold
7. On the homotopy groups of PL/O; the Poincaré conjecture in dimension five
8. Groups of diffeomorphisms
9. The rational Pontrjagin classes

Part VI – Pseudomanifolds

1. The differentiable bordism
2. The bordism of pseudomanifolds
3. The singularities of the join type
4. Sullivan's theory of the local obstruction to a topological resolution of singularities

Bibliography

Index

Preface

This book presents some of the main themes in the development of the combinatorial topology of high-dimensional manifolds, which took place roughly during the decade 1960–70 when new ideas and new techniques allowed the discipline to emerge from a long period of lethargy.

The first great results came at the beginning of the decade. I am referring here to the weak Poincaré conjecture and to the uniqueness of the PL and differentiable structures of Euclidean spaces, which follow from the work of J Stallings and E C Zeeman. Part I is devoted to these results, with the exception of the first two sections, which offer a historical picture of the salient questions which kept the topologists busy in those days. It should be noted that Smale proved a strong version of the Poincaré conjecture also near the beginning of the decade. Smale’s proof (his h -cobordism theorem) will not be covered in this book.

The principal theme of the book is the problem of the existence and the uniqueness of triangulations of a topological manifold, which was solved by R Kirby and L Siebenmann towards the end of the decade.

This topic is treated using the “immersion theory machine” due to Haefliger and Poenaru. Using this machine the geometric problem is converted into a bundle lifting problem. The obstructions to lifting are identified and their calculation is carried out by a geometric method which is known as Handle-Straightening.

The treatment of the Kirby–Siebenmann theory occupies the second, the third and the fourth part, and requires the introduction of various other topics such as the theory of microbundles and their classifying spaces and the theory of immersions and submersions, both in the topological and PL contexts.

The fifth part deals with the problem of smoothing PL manifolds, and with related subjects including the group of diffeomorphisms of a differentiable manifold.

The sixth and last part is devoted to the bordism of pseudomanifolds a topic which is connected with the representation of homology classes according to Thom and Steenrod. For the main part it describes some of Sullivan’s ideas on topological resolution of singularities.

The monograph is necessarily incomplete and fragmentary, for example the important topics of h -cobordism and surgery are only stated and for these the reader will have to consult the bibliography. However the book does aim to present a few of the wide variety of issues which made the decade 1960–70 one of the richest and most exciting periods in the history of manifold topology.

Acknowledgements

(To be extended)

The short proof of 4.7 in the codimension 3 case, which avoids piping, is hitherto unpublished. It was found by Zeeman in 1966 and it has been clarified for me by Colin Rourke.

The translation of the original Italian version is by Rosa Antolini.

Note about cross-references

Cross references are of the form Theorem 3.7, which means the theorem in subsection 3.7 (of the current part) or of the form III.3.7 which means the results of subsection 3.7 in part III. In general results are unnumbered where reference to the subsection in which they appear is unambiguous but numbered within that subsection otherwise. For example Corollary 3.7.2 is the second corollary within subsection 3.7.

Note about inset material

Some of the material is inset and marked with the symbol ▼ at the start and ▲ at the end. This material is either of a harder nature or of side interest to the main theme of the book and can safely be omitted on first reading.

Notes about bibliographic references and ends of proofs

References to the bibliography are in square brackets, eg [Kan 1955]. Similar looking references given in round brackets eg (Kan 1955) are for attribution and do not refer to the bibliography.

The symbol □ is used to indicate either the end of a proof or that a proof is not given.

Part I : PL Topology

1 Introduction

This book gives an exposition of: the triangulation problem for a topological manifold in dimensions strictly greater than four; the smoothing problem for a piecewise-linear manifold; and, finally, of some of Sullivan's ideas about the topological resolution of singularities.

The book is addressed to readers who, having a command of the basic notions of combinatorial and differential topology, wish to gain an insight into those which we still call the golden years of the topology of manifolds.¹

With this aim in mind, rather than embarking on a detailed analytical introduction to the contents of the book, I shall confine myself to a historically slanted outline of the triangulation problem, hoping that this may be of help to the reader.

A piecewise-linear manifold, abbreviated PL, is a topological manifold together with a maximal atlas whose transition functions between open sets of \mathbb{R}_+^n admit a graph that is a locally finite union of simplexes.

There is no doubt that the unadorned topological manifold, stripped of all possible additional structures (differentiable, PL, analytic etc) constitutes an object of remarkable charm and that the same is true of the equivalences, namely the homeomorphisms, between topological manifolds. Due to a lack of means at one's disposal, the study of such objects, which define the so called topological category, presents huge and frustrating difficulties compared to the admittedly hard study of the analogous PL category, formed by the PL manifolds and the PL homeomorphisms.

A significant fact, which highlights the kind of pathologies affecting the topological category, is the following. It is not difficult to prove that the group of PL self-homeomorphisms of a connected boundariless PL manifold M^m acts transitively not just on the points of M , but also on the PL m -discs contained in M . On the contrary, the group of topological self-homeomorphisms indeed

¹The book may also be used as an introduction to A Casson, D Sullivan, M Armstrong, C Rourke, G Cooke, *The Hauptvermutung Book*, K-monographs in Mathematics 1996.

acts transitively on the points of M , but not on the topological m -discs of M . The reason dates back to an example of Antoine's (1920), better known in the version given by Alexander and usually called the Alexander horned sphere. This is a the boundary of a *topological* embedding $h: D^3 \rightarrow \mathbb{R}^3$ (where D^3 is the standard disc $x^2 + y^2 + z^2 \leq 1$), such that $\pi_1(\mathbb{R}^3 \setminus h(D^3)) \neq 1$. It is clear that there cannot be any automorphism of \mathbb{R}^3 taking $h(D^3)$ to D^3 , since $\mathbb{R}^3 \setminus D^3$ is simply connected.

As an observation of a different nature, let us recall that people became fairly easily convinced that simplicial homology, the first notion of homology to be formalised, is invariant under PL automorphisms; however its invariance under topological homeomorphisms immediately appeared as an almost intractable problem.

It then makes sense to suppose that the thought occurred of transforming problems related to the topological category into analogous ones to be solved in the framework offered by the PL category. From this attitude two questions naturally emerged: is a given topological manifold homeomorphic to a PL manifold, more generally, is it triangulable? In the affirmative case, is the resulting PL structure unique up to PL homeomorphisms?

The second question is known as *die Hauptvermutung* (the main conjecture), originally formulated by Steinitz and Tietze (1908) and later taken up by Kneser and Alexander. The latter, during his speech at the International Congress of Mathematicians held in Zurich in 1932, stated it as one of the major problems of topology.

The philosophy behind the conjecture is that the relation M_1 topologically equivalent to M_2 should be as close as possible to the relation M_1 combinatorially equivalent to M_2 .

We will first discuss the Hauptvermutung, which is, in some sense, more important than the problem of the existence of triangulations, since most known topological manifolds are already triangulated.

Let us restate the conjecture in the form and variations that are currently used. Let Θ_1, Θ_2 be two PL structures on the topological manifold M . Then Θ_1, Θ_2 are said to be *equivalent* if there exists a PL homeomorphism $f: M_{\Theta_1} \rightarrow M_{\Theta_2}$, they are said to be *isotopy equivalent* if such an f can be chosen to be isotopic to the identity and *homotopy equivalent* if f can be chosen to be homotopic to the identity.

The Hauptvermutung for surfaces and three-dimensional manifolds was proved by Kerékjártó (1923) and Moise (1952) respectively. We owe to Papakyriakopoulos (1943) the solution to a generalised Hauptvermutung, which is valid for any 2-dimensional polyhedron.

We observe, however, that in those same years the topological invariance of homology was being established by other methods.

For the class of C^∞ triangulations of a differentiable manifold, Whitehead proved an isotopy Hauptvermutung in 1940, but in 1960 Milnor found a polyhedron of dimension six for which the generalised Hauptvermutung is false. This polyhedron is not a PL manifold and therefore the conjecture remained open for manifolds.

Plenty of water passed under the bridge. Thom suggested that a structure on a manifold should correspond to a section of an appropriate fibration. Milnor introduced microbundles and proved that S^7 supports twenty-eight differentiable structures which are inequivalent from the C^∞ viewpoint, thus refuting the C^∞ Hauptvermutung. The simplicial language gained ground, so that the set of PL structures on M could be replaced effectively by a topological space $\text{PL}(M)$ whose path components correspond to the isotopy classes of PL structures on M . Hirsch in the differentiable case and Haefliger and Poenaru in the PL case studied the problem of immersions between manifolds. They conceived an approach to immersion theory which validates Thom's hypothesis and establishes a homotopy equivalence between the space of immersions and the space of monomorphisms of the tangent microbundles. This reduces theorems of this kind to a test of a few precise axioms followed by the classical obstruction theory to the existence and uniqueness of sections of bundles.

Inspired by this approach, Lashof, Rothenberg, Casson, Sullivan and other authors gave significant contributions to the triangulation problem of topological manifolds, until in 1969 Kirby and Siebenmann shocked the mathematical world by providing the following final answer to the problem.

Theorem (Kirby–Siebenmann) *If M^m is an unbounded PL manifold and $m \geq 5$, then the whole space $\text{PL}(M)$ is homotopically equivalent to the space of maps $K(\mathbb{Z}/2, 3)^M$.*

If $m \leq 3$, then $\text{PL}(M)$ is contractible (Moise). □

$K(\mathbb{Z}/2, 3)$ denotes, as usual, the Eilenberg–MacLane space whose third homotopy group is $\mathbb{Z}/2$. Consequently the isotopy classes of PL structures on M are given by $\pi_0(\text{PL}(M)) = [M, K(\mathbb{Z}/2, 3)] = H^3(M, \mathbb{Z}/2)$. The isotopy Hauptvermutung was in this way disproved. In fact, there are two isotopy classes of PL structures on $S^3 \times \mathbb{R}^2$ and, moreover, Siebenmann proved that $S^3 \times S^1 \times S^1$ admits two PL structures inequivalent up to isomorphism and, consequently, up to isotopy or homotopy.

The Kirby–Siebenmann theorem reconfirms the validity of the Hauptvermutung for \mathbb{R}^m ($m \neq 4$) already established by Stallings in 1962.

The homotopy-Hauptvermutung was previously investigated by Casson and Sullivan (1966), who provided a solution which, for the sake of simplicity, we will enunciate in a particular case.

Theorem (Casson–Sullivan) *Let M^m be a compact simply-connected manifold without boundary with $m \geq 5$, such that $H^4(M, \mathbb{Z})$ has no 2-torsion. Then two PL structures on M are homotopic.*² □

With respect to the existence of PL structures, Kirby and Siebenmann proved, as a part of the above theorem, that: *A boundariless M^m , with $m \geq 5$, admits a PL structure if and only if a single obstruction $k(M) \in H^4(M, \mathbb{Z}/2)$ vanishes.*

Just one last comment on the triangulation problem. It is still unknown whether a topological manifold of dimension ≥ 5 can *always* be triangulated by a simplicial complex that is not necessarily a combinatorial manifold. Certainly there exist triangulations that are not combinatorial, since Edwards has shown that the double suspension of a three-dimensional homological sphere is a genuine sphere.

Finally, the reader will have noticed that the four-dimensional case has always been excluded. This is a completely different and more recent story, which, thanks to Freedman and Donaldson, constitutes a revolutionary event in the development of the topology of manifolds. As evidence of the schismatic behaviour of the fourth dimension, here we have room only for two key pieces of information with which to whet the appetite:

- (a) \mathbb{R}^4 admits uncountably many PL structures.
- (b) ‘Few’ four-dimensional manifolds are triangulable.

²This book will not deal with this most important and difficult result. The reader is referred to [Casson, Sullivan, Armstrong, Rourke, Cooke 1996].

2 Problems, conjectures, classical results

This section is devoted to a sketch of the state of play in the field of combinatorial topology, as it presented itself during the sixties. Brief information is included on developments which have occurred since the sixties.

Several of the topics listed here will be taken up again and developed at leisure in the course of the book.

An *embedding* of a topological space X into a topological space Y is a continuous map $\mu: X \rightarrow Y$, which restricts to a homeomorphism between X and $\mu(X)$.

Two embeddings, μ and ν , of X into Y are *equivalent*, if there exists a homeomorphism $h: Y \rightarrow Y$ such that $h\mu = \nu$.

2.1 Knots of spheres in spheres

A *topological knot* of *codimension* c in the sphere S^n is an embedding $\nu: S^{n-c} \rightarrow S^n$. The knot is said to be *trivial* if it is equivalent to the standard knot, that is to say to the natural inclusion of S^{n-c} into S^n .

Codimension 1 – the Schoenflies conjecture

Topological Schoenflies conjecture Every knot of codimension one in S^n is trivial.

- The conjecture is true for $n = 2$ (Schoenflies 1908) and plays an essential role in the triangulation of surfaces. The conjecture is false in general, since Antoine and Alexander (1920–24) have knotted S^2 in S^3 .

A knot $\nu: S^{n-c} \rightarrow S^n$ is *locally flat* if there exists a covering of S^{n-c} by open sets such that on each open U of the covering the restriction $\nu: U \rightarrow S^n$ extends to an embedding of $U \times \mathbb{R}^c$ into S^n .

If $c = 1$, locally flat = locally bicollared:

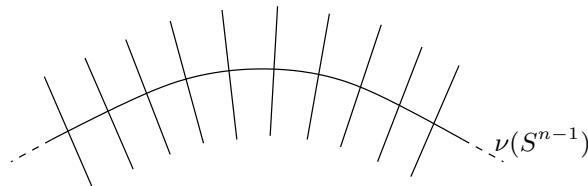

Weak Schoenflies Conjecture Every locally flat knot is trivial.

- The conjecture is true (Brown and Mazur–Morse 1960).

Canonicalness of the weak Schoenflies problem

The weak Schoenflies problem may be enunciated by saying that any embedding $\mu: S^{n-1} \times [-1, 1] \rightarrow \mathbb{R}^n$ extends to an embedding $\boldsymbol{\mu}: D^n \rightarrow \mathbb{R}^n$, with $\boldsymbol{\mu}(x) = \mu(x, 0)$ for $x \in S^{n-1}$.

Consider μ and $\boldsymbol{\mu}$ as elements of $\text{Emb}(S^{n-1} \times [-1, 1], \mathbb{R}^n)$ and $\text{Emb}(D^n, \mathbb{R}^n)$ respectively, ie, of the spaces of embeddings with the compact open topology.

[Huebsch and Morse 1960/1963] proved that it is possible to choose the solution $\boldsymbol{\mu}$ to the Schoenflies problem μ in such a way that the correspondence $\mu \rightarrow \boldsymbol{\mu}$ is continuous as a map between the embedding spaces. We describe this by saying that $\boldsymbol{\mu}$ depends *canonically* on μ and that the solution to the Schoenflies problem is *canonical*. Briefly, if the problems μ and μ' are close, their solutions too may be assumed to be close. See also [Gauld 1971] for a far shorter proof.

The definitions and the problems above are immediately transposed into the PL case, but the answers are different.

PL–Schoenflies Conjecture Every PL knot of codimension one in S^n is trivial.

- The conjecture is true for $n \leq 3$, Alexander (1924) proved the case $n = 3$. For $n > 3$ the conjecture is still open; if the $n = 4$ case is proved, then the higher dimensional cases will follow.

Weak PL–Schoenflies Conjecture Every PL knot, of codimension one and locally flat in S^n , is trivial.

- The conjecture is true for $n \neq 4$ (Alexander $n < 4$, Smale $n \geq 5$).

Weak Differentiable Schoenflies Conjecture Every differentiable knot of codimension one in S^n is setwise trivial, ie, there is a diffeomorphism of S^n carrying the image to the image of the standard embedding.

- The conjecture is true for $n \neq 4$ (Smale $n > 4$, Alexander $n < 4$).

The strong Differentiable Schoenflies Conjecture, that every differentiable knot of codimension one in S^n is trivial is false for $n > 5$ because of the existence of exotic diffeomorphisms of S^n for $n \geq 6$ [Milnor 1958].

A less strong result than the PL Schoenflies problem is a classical success of the Twenties.

Theorem (Alexander–Newman) *If B^n is a PL disc in S^n then the closure $S^n - B^n$ is itself a PL disc.* \square

The result holds also in the differentiable case (Munkres).

Higher codimensions

Theorem [Stallings 1963] *Every locally flat knot of codimension $c \neq 2$ is trivial.* \square

Theorem [Zeeman 1963] *Every PL knot of codimension $c \geq 3$ is trivial.* \square

Zeeman's theorem does not carry over to the differentiable case, since Haefliger (1962) has differentiably knotted S^{4k-1} in S^{6k} ; nor it can be transposed into the topological case, where there exist knots (necessarily not locally flat if $c \neq 2$) in all codimensions $0 < c < n$.

2.2 The annulus conjecture

PL annulus theorem [Hudson–Zeeman 1964] *If B_1^n, B_2^n are PL discs in S^n , with $B_1 \subset \text{Int } B_2$, then*

$$\overline{B_2 - B_1} \approx_{PL} \dot{B}_1 \times [0, 1]. \quad \square$$

Topological annulus conjecture Let $\mu, \nu: S^{n-1} \rightarrow \mathbb{R}^n$ be two locally flat topological embeddings with S_μ contained in the interior of the disc bounded by S_ν . Then there exists an embedding $\lambda: S^{n-1} \times I \rightarrow \mathbb{R}^n$ such that

$$\lambda(x, 0) = \mu(x) \quad \text{and} \quad \lambda(x, 1) = \nu(x).$$

- The conjecture is true (Kirby 1968 for $n > 4$, Quinn 1982 for $n=4$).

The following beautiful result is connected to the annulus conjecture:

Theorem [Cernavskii 1968, Kirby 1969, Edwards–Kirby 1971] *The space $\mathcal{H}(\mathbb{R}^n)$ of homeomorphisms of \mathbb{R}^n with the compact open topology is locally contractible.* \square

2.3 The Poincaré conjecture

A *homotopy sphere* is, by definition, a closed manifold of the homotopy type of a sphere.

Topological Poincaré conjecture A homotopy sphere is a topological sphere.

- The conjecture is true for $n \neq 3$ (Newman 1966 for $n > 4$, Freedman 1982 for $n=4$)

Weak PL–Poincaré conjecture A PL homotopy sphere is a topological sphere.

- The conjecture is true for $n \neq 3$. This follows from the topological conjecture above, but was first proved by Smale, Stallings and Zeeman (Smale and Stallings 1960 for $n \geq 7$, Zeeman 1961/2 for $n \geq 5$, Smale and Stallings 1962 for $n \geq 5$).

(Strong) PL–Poincaré conjecture A PL homotopy sphere is a PL sphere.

- The conjecture is true for $n \neq 3, 4$, (Smale 1962, for $n \geq 5$).

In the differentiable case the weak Poincaré conjecture is true for $n \neq 3$ (follows from the Top or PL versions) the strong one is false in general (Milnor 1958).

Notes For $n = 3$, the weak and the strong versions are equivalent, due to the theorems on triangulation and smoothing of 3–manifolds. Therefore the Poincaré conjecture, *still open*, assumes a unique form: a homotopy 3–sphere (Top, PL or Diff) is a 3–sphere. For $n = 4$ the strong PL and Diff conjectures are similarly equivalent and are also *still open*. Thus, for $n = 4$, we are today in a similar situation as that in which topologists were during 1960/62 before Smale proved the strong PL high-dimensional Poincaré conjecture.

2.4 Structures on manifolds

Structures on \mathbb{R}^n

Theorem [Stallings 1962] *If $n \neq 4$, \mathbb{R}^n admits a unique structure of PL manifold and a unique structure of C^∞ manifold.* \square

Theorem (Edwards 1974) *There exist non combinatorial triangulations of \mathbb{R}^n , $n \geq 5$.* \square

Therefore \mathbb{R}^n does not admit, in general, a unique polyhedral structure.

Theorem \mathbb{R}^4 admits uncountably many PL or C^∞ structures.

This is one of the highlights following from the work of Casson, Edwards (1973-75), Freedman (1982), Donaldson (1982), Gompf (1983/85), Taubes (1985). The result stated in the theorem is due to Taubes. An excellent historical and mathematical account can be found in [Kirby 1989].

PL-structures on spheres

Theorem If $n \neq 4$, S^n admits a unique structure of PL manifold. □

This result is classical for $n \leq 2$, it is due to Moise (1952) for $n = 3$, and to Smale (1962) for $n > 4$.

Theorem (Edwards 1974) *The double suspension of a PL homology sphere is a topological sphere.* □

Therefore there exist non combinatorial triangulations of spheres. Consequently spheres, like Euclidean spaces, do not admit, in general, a unique polyhedral structure.

Smooth structures on spheres

Let $C(S^n)$ be the set of orientation-preserving diffeomorphism classes of C^∞ structures on S^n . For $n \neq 4$ this can be given a group structure by using connected sum and is the same as the group of differentiable homotopy spheres Γ_n for $n > 4$.

Theorem Assume $n \neq 4$. Then

- (a) $C(S^n)$ is finite,
- (b) $C(S^n)$ is the trivial group for $n \leq 6$ and for some other values of n , while, for instance, $C(S^{4k-1}) \neq \{1\}$ for all $k \geq 2$. □

The above results are due to Milnor (1958), Smale (1959), Munkres (1960), Kervaire-Milnor (1963).

The 4-dimensional case

It is unknown whether S^4 admits exotic PL and C^∞ structures. The two problems are equivalent and they are also both equivalent to the strong four-dimensional PL and C^∞ Poincaré conjecture. If $C(S^4)$ is a group then the four-dimensional PL and C^∞ Poincaré conjectures reduce to the PL and C^∞ Schoenflies conjectures (all unsolved).

A deep result of Cerf's (1962) implies that there is no C^∞ structure on S^4 which is an effectively twisted sphere, ie, a manifold obtained by glueing two copies of the standard disk through a diffeomorphism between their boundary spheres. Note that the PL analogue of Cerf's result is an easy exercise: effectively twisted PL spheres cannot exist (in any dimension) since there are no exotic PL automorphisms of S^n .

These results fall within the ambit of the problems listed below.

Structure problems for general manifolds

Problem 1 Is a topological manifold of dimension n homeomorphic to a PL manifold?

- Yes for $n \leq 2$ (Radò 1924/26).
- Yes for $n = 3$ (Moise, 1952).
- No for $n = 4$ (Donaldson 1982).
- No for $n > 4$: in each dimension > 4 there are non-triangulable topological manifolds (Kirby–Siebenmann 1969).

Problem 2 Is a topological manifold homeomorphic to a polyhedron?

- Yes if $n \leq 3$ (Radò, Moise).
- No for $n = 4$ (Casson, Donaldson, Taubes, see [Kirby Problems 4.72]).
- Unknown for $n > 5$, see [Kirby op cit].

Problem 3 Is a polyhedron, which is a topological manifold, also a PL manifold?

- Yes if $n \leq 3$.
- Unknown for $n = 4$, see [Kirby op cit]. If the 3-dimensional Poincaré conjecture holds, then the problem can be answered in the affirmative, since the link of a vertex in any triangulation of a 4-manifold is a simply connected 3-manifold.
- No if $n > 4$ (Edwards 1974).

Problem 4 (Hauptvermutung for polyhedra) If two polyhedra are homeomorphic, are they also PL homeomorphic?

- Negative in general (Milnor 1961).

Problem 5 (Hauptvermutung for manifolds) If two PL manifolds are homeomorphic, are they also PL homeomorphic?

- Yes for $n = 1$ (trivial).
- Yes for $n = 2$ (classical).
- Yes for $n = 3$ (Moise).
- No for $n = 4$ (Donaldson 1982).
- No for $n > 4$ (Kirby–Siebenmann–Sullivan 1967–69).

Problem 6 (C^∞ Hauptvermutung) Are two homeomorphic C^∞ manifolds also diffeomorphic?

- For $n \leq 6$ the answers are the same as the last problem.
- No for $n \geq 7$, for example there are 28 C^∞ differential structures on S^7 (Milnor 1958).

Problem 7 Does a C^∞ manifold admit a PL manifold structure which is compatible (according to Whitehead) with the given C^∞ structure?

In the affirmative case is such a PL structure unique?

- The answer is affirmative to both questions, with no dimensional restrictions. This is the venerable Whitehead Theorem (1940).

Note A PL structure being *compatible* with a C^∞ structure means that the transition functions relating the PL atlas and the C^∞ atlas are piecewise-differentiable maps, abbreviated PD.

By exchanging the roles of PL and C^∞ one obtains the so called and much more complicated “smoothing problem”.

Problem 8 Does a PL manifold M^n admit a C^∞ structure which is Whitehead compatible?

- Yes for $n \leq 7$ but no in general. There exists an obstruction theory to smoothing, with obstructions $\alpha_i \in H^{i+1}(M; \Gamma_i)$, where Γ_i is the (finite) group of differentiable homotopy spheres (Cairns, Hirsch, Kervaire, Lashof, Mazur, Munkres, Milnor, Rothenberg et al \sim 1965).
- The C^∞ structure is unique for $n \leq 6$.

Problem 9 Does there always exist a C^∞ structure on a PL manifold, possibly not Whitehead-compatible?

- No in general (Kervaire's counterexample, 1960).

3 Polyhedra and categories of topological manifolds

In this section we will introduce the main categories of geometric topology. These are defined through the concept of supplementary structure on a topological manifold. This structure is usually obtained by imposing the existence of an atlas which is compatible with a pseudogroup of homeomorphisms between open sets in Euclidean spaces.

We will assume the reader to be familiar with the notions of simplicial complex, simplicial map and subdivision. The main references to the literature are [Zeeman 1963], [Stallings 1967], [Hudson 1969], [Glaser 1970], [Rourke and Sanderson 1972].

3.1 The combinatorial category

A *locally finite simplicial complex* K is a collection of simplexes in some Euclidean space E , such that:

- (a) $A \in K$ and B is a face of A , written $B < A$, then $B \in K$.
- (b) If $A, B \in K$ then $A \cap B$ is a common face, possibly empty, of both A and B .
- (c) Each simplex of K has a neighbourhood in E which intersects only a finite number of simplexes of K .

Often it will be convenient to confuse K with its *underlying topological space*

$$|K| = \bigcup_{A \in K} A$$

which is called a *Euclidean polyhedron*.

We say that a map $f: K \rightarrow L$ is *piecewise linear*, abbreviated PL, if there exists a linear subdivision K' of K such that f sends each simplex of K' linearly into a simplex of L .

It is proved, in a non trivial way, that the locally finite simplicial complexes and the PL maps form a category with respect to composition of maps. This is called the *combinatorial category*.

There are three important points to be highlighted here which are also non trivial to establish:

- (a) If $f: K \rightarrow L$ is PL and K, L are *finite*, then there exist subdivisions $K' \triangleleft K$ and $L' \triangleleft L$ such that $f: K' \rightarrow L'$ is simplicial. Here \triangleleft is the symbol used to indicate subdivision.

- (b) A theorem of Runge ensures that an open set U of a simplicial complex K or, more precisely, of $|K|$, can be *triangulated*, ie, underlies a locally finite simplicial complex, in a way such that the inclusion map $U \subset K$ is PL. Furthermore such a triangulation is unique up to a PL homeomorphism. For a proof see [Alexandroff and Hopf 1935, p. 143].
- (c) A PL map, which is a homeomorphism, is a PL isomorphism, ie, the inverse map is automatically PL. This does not happen in the differentiable case as shown by the function $f(x) = x^3$ for $x \in \mathbb{R}$.

As evidence of the little flexibility of PL isomorphisms consider the differentiable map of \mathbb{R} into itself

$$f(x) = \begin{cases} x + \frac{e^{-1/x^2}}{4} \sin\left(\frac{1}{x}\right) & x \neq 0 \\ 0 & x = 0. \end{cases}$$

This is even a C^∞ diffeomorphism but it can not in any way be well approximated by a PL map, since the origin is an accumulation point of isolated fixed points (Siebenmann).

If $S \subset K$ is a subset made of simplexes, we call the *simplicial closure* of S the smallest subcomplex of K which contains S :

$$\bar{S} := \{B \in K : \exists A \in S \text{ with } B < A\}.$$

In other words we add to the simplexes of S all their faces. Since, clearly, $|S| = |\bar{S}|$, we will say that S *generates* \bar{S} .

Let v be a vertex of K , then the *star of v in K* , written $S(v, K)$, is the subcomplex of K generated by all the simplexes which admit v as a vertex, while the *link of v in K* , written $L(v, K)$, is the subcomplex consisting of all the simplexes of $S(v, K)$ which do not admit v as a vertex. The most important property of the link is the following: if $K' \triangleleft K$ then $L(v, K) \approx_{\text{PL}} L(v, K')$.

K is called a n -dimensional *combinatorial manifold without boundary*, if the link of each vertex is a PL n -sphere. More generally, K is a combinatorial n -manifold *with boundary* if the link of each vertex is a PL n -sphere or PL n -ball. (PL *spheres* and *balls* will be defined precisely in subsection 3.6 below.) It can be verified that the subcomplex $\bar{K} = \partial K \subset K$ generated by all the $(n-1)$ -simplexes which are faces of *exactly one* n -simplex is itself a combinatorial $(n-1)$ -manifold without boundary.

3.2 Polyhedra and manifolds

Until now we have dealt with objects such as simplicial complexes which are, by definition, contained in a given Euclidean space. Yet, as happens in the case of differentiable manifolds, it is advisable to introduce the notion of a polyhedron in an intrinsic manner, that is to say independent of an ambient Euclidean space.

Let P be a topological space such that each point in P admits an open neighbourhood U and a homeomorphism

$$\varphi: U \rightarrow |K|$$

where K is a locally finite simplicial complex. Both U and φ are called a coordinate chart. Two charts are PL *compatible* if they are related by a PL isomorphism on their intersection.

A *polyhedron* is a metrisable topological space endowed with a maximal atlas of PL compatible charts. The atlas is called a *polyhedral structure*. For example, a simplicial complex is a polyhedron in a natural way.

A PL *map* of polyhedra is defined in the obvious manner using charts. Now one can construct the *polyhedral category*, whose objects are the polyhedra and whose morphisms are the PL maps.

It turns out to be a non trivial fact that each polyhedron is PL homeomorphic to a simplicial complex.

A *triangulation* of a polyhedron P is a PL homeomorphism $t: |K| \rightarrow P$, where $|K|$ is a Euclidean polyhedron. When there is no danger of confusion we will identify, through the map t , the polyhedron P with $|K|$ or even with K .

Alternative definition Firstly we will extend the concept of triangulation. A *triangulation* of a *topological space* X is a homeomorphism $t: |K| \rightarrow X$, where K is a simplicial complex. A *polyhedron* is a pair (P, \mathcal{F}) , where P is a topological space and \mathcal{F} is a maximal collection of PL *compatible triangulations*. This means that, if t_1, t_2 are two such triangulations, then $t_2^{-1}t_1$ is a PL map. The reader who is interested in the equivalence of the two definitions of polyhedron, ie, the one formulated using local triangulations and the latter formulated using global triangulations, can find some help in [Hudson 1969, pp. 76-87].

[E C Zeeman 1963] generalised the notion of a *polyhedron* to that of a *polyspace*. As an example, \mathbb{R}^∞ is not a polyhedron but it is a polyspace, and therefore it makes sense to talk about PL maps defined on or with values in \mathbb{R}^∞ .

$P_0 \subset P$ is a *closed subpolyhedron* if there exists a triangulation of P which restricts to a triangulation of P_0 .

A full subcategory of the polyhedral category of central importance is that consisting of PL *manifolds*. Such a manifold, *of dimension m* , is a polyhedron M whose charts take values in open sets of \mathbb{R}^m .

When there is no possibility of misunderstanding, the category of PL manifolds and PL maps is abbreviated to the PL *category*. It is a non trivial fact that every triangulation of a PL manifold is a combinatorial manifold and actually, as happens for the polyhedra, this provides an *alternative definition*: a PL manifold consists of a polyhedron M such that each triangulation of M is a combinatorial manifold. The reader who is interested in the equivalence of the two definitions of PL manifold can refer to [Dedecker 1962].

3.3 Structures on manifolds

The main problem upon which most of the geometric topology is based is that of classifying and comparing the various supplementary structures that can be imposed on a topological manifold, with a particular interest in the piecewise linear and differentiable structures.

The definition of PL manifold by means of an atlas given in the previous subsection is a good example of the more general notion of manifold with structure which we now explain. For the time being we will limit ourselves to the case of manifolds without boundary.

A *pseudogroup* Γ on a Euclidean space E is a category whose objects are the open subsets of E . The morphisms are given by a class of homeomorphisms between open sets, which is closed with respect to composition, restriction, and inversion; furthermore $1_U \in \Gamma$ for each open set U . Finally we require the class to be *locally defined*. This means that if Γ_0 is the set of all the germs of the morphisms of Γ and $f: U \rightarrow V$ is a homeomorphism whose germ at every point of U is in Γ_0 , then $f \in \Gamma$.

Examples

- (a) Γ is trivial, ie, it consists of the identity maps. This is the smallest pseudogroup.
- (b) Γ consists of all the homeomorphisms. This is the biggest pseudogroup, which we will denote Top.
- (c) Γ consists of all the *stable* homeomorphisms according to [Brown and Gluck 1964]. This is denoted SH. We will return to this important pseudogroup in IV, section 9.

- (d) Γ consists of all the C^r homeomorphisms whose inverses are C^r .
- (e) Γ consists of all the C^∞ diffeomorphisms, denoted by Diff, or all the C^ω diffeomorphisms (real analytic), or all C^Ω diffeomorphisms (complex analytic).
- (f) Γ consists of all the Nash homeomorphisms.
- (g) Γ consists of all the PL homeomorphisms, denoted by PL.
- (h) Γ is a pseudogroup associated to foliations (see below).
- (i) E could be a Hilbert space, in which case an example is offered by the Fredholm operators.

Let us recall that a *topological manifold* of dimension m is a metrisable topological space M , such that each point x in M admits an open neighbourhood U and a homeomorphism φ between U and an open set of \mathbb{R}^m . Both U and φ are called a *chart around x* . A Γ *structure* Θ on M is a maximal atlas Γ -compatible. This means that, if $(U_\alpha, \varphi_\alpha)$ and (U_β, φ_β) are two charts around x , then $\varphi_\beta \circ \varphi_\alpha^{-1}$ is in Γ , where the composition is defined.

If Γ is the pseudogroup of PL homeomorphisms of open sets of \mathbb{R}^m , Θ is nothing but a *PL structure* on the topological manifold M . If Γ is the pseudogroup of the diffeomorphisms of open sets of \mathbb{R}^m , then Θ is a *C^∞ structure* on M . If, instead, the diffeomorphisms are C^r , then we have a *C^r -structure* on M . Finally if $\Gamma = \text{SH}$, Θ is called a *stable structure* on M . Another interesting example is described below.

Let $\pi: \mathbb{R}^m \rightarrow \mathbb{R}^p$ be the Cartesian projection onto the first p coordinates and let Γ_m be one of the pseudogroups PL, C^∞ , Top, on \mathbb{R}^m considered above. We define a new pseudogroup $\mathcal{F}_\Gamma^p \subset \Gamma_m$ by requiring that $f: U \rightarrow V$ is in \mathcal{F}_Γ^p if there is a commutative diagram

$$\begin{array}{ccc} U & \xrightarrow{f} & V \\ \pi \downarrow & & \downarrow \pi \\ \pi(U) & \xrightarrow{g} & \pi(V) \end{array}$$

with $f \in \Gamma_m$, $g \in \Gamma_p$. A \mathcal{F}_Γ^p -structure on M is called a Γ -*structure with a foliation of codimension p* . Therefore we have the notion of *manifold with foliation*, either topological, PL or differentiable.

A Γ -*manifold* is a pair (M, Θ) , where M is a topological manifold and Θ is a Γ -structure on M . We will often write M_Θ , or even M when the Γ -structure Θ is obvious from the context. If $f: M' \rightarrow M_\Theta$ is a homeomorphism, the Γ *structure*

induced on M' , $f^*(\Theta)$, is the one which has a composed homeomorphism as a typical chart

$$f^{-1}(U) \xrightarrow{f} U \xrightarrow{\varphi} \varphi(U)$$

where φ is a chart of Θ on M .

From now on we will concentrate only on the pseudogroups $\Gamma = \text{Top, PL, Diff}$.

A homeomorphism $f: M_\Theta \rightarrow M'_{\Theta'}$ of Γ -manifolds is a Γ -isomorphism if $\Theta = f^*(\Theta')$. More generally, a Γ -map $f: M \rightarrow N$ between two Γ -manifolds is a continuous map f of the underlying topological manifolds, such that, written locally in coordinates it is a topological PL or C^∞ map, according to the pseudogroup chosen. Then we have the category of the Γ -manifolds and Γ -maps, in which the isomorphisms are the Γ -isomorphisms described above and usually denoted by the symbol \approx_Γ , or simply \approx .

3.4 Isotopy

In the category of topological spaces and continuous maps, an isotopy of X is a homeomorphism $F: X \times I \rightarrow X \times I$ which respects the levels, ie, $p = pF$, where p is the projection on I .

Such an F determines a continuous set of homeomorphisms $f_t: X \rightarrow X$ through the formula

$$F(x, t) = (f_t(x), t) \quad t \in I.$$

Usually, in order to reduce the use of symbols, we write F_t instead of f_t . The isotopy F is said to be ambient if $f_0 = 1_X$. We say that F fixes $Z \subset X$, or that F is relative to Z , if $f_t|_Z = 1_Z$ for each $t \in I$; we say that F has support in $W \subset X$ if F it fixes $X - W$. Two topological embeddings $\lambda, \mu: Y \rightarrow X$ are isotopic if there exists an embedding $H: Y \times I \rightarrow X \times I$, which preserves the levels and such that $h_0 = \lambda$ and $h_1 = \mu$. The embeddings are ambient isotopic if there exists H which factorises through an ambient isotopy, F , of X :

$$\begin{array}{ccc} Y \times I & \xrightarrow{H} & X \times I \\ & \searrow \lambda \times I & \nearrow F \\ & X \times I & \end{array}$$

and, in this case, we will say that F extends H . The embedding H is said to be an isotopy between λ and μ .

The language of isotopies can be applied, with some care, to each of the categories Top, PL, Diff.

3.5 Boundary

The notion of Γ -manifold with boundary and its main properties do not present any problem. It is sufficient to require that the pseudogroup Γ is defined satisfying the usual conditions, but starting from a class of homeomorphisms of the open sets of the halfspace $\mathbb{R}_+^m = \{(x_1, \dots, x_m) \in \mathbb{R}^m : x_1 \geq 0\}$. The points in M that correspond, through the coordinate charts, to points in the hyperplane, $\{(x_1, \dots, x_m) \in \mathbb{R}_+^m : x_1 = 0\}$ define the boundary ∂M or \dot{M} of M . This can be proved to be an $(m - 1)$ -dimensional Γ -manifold without boundary. The complement of ∂M in M is the interior of M , denoted either by $\text{Int } M$ or by $\overset{\circ}{M}$. A closed Γ -manifold is defined as a compact Γ -manifold without boundary. A Γ -collar of ∂M in M is a Γ -embedding

$$\gamma: \partial M \times I \rightarrow M$$

such that $\gamma(x, 0) = x$ and $\gamma(\partial M \times [0, 1))$ is an open neighbourhood of ∂M in M . The fact that *the boundary of a Γ -manifold always admits a Γ -collar, which is unique up to Γ -ambient isotopy* is very important and non trivial.

3.6 Notation

Now we wish to establish a unified notation for each of the two standard objects which are mentioned most often, ie, the sphere S^{m-1} and the disc D^m .

In the PL category, D^m means either the cube $I^m = [0, 1]^m \subset \mathbb{R}^m$ or the simplex

$$\Delta^m = \{(x_1, \dots, x_m) \in \mathbb{R}^m : x_i \geq 0 \text{ and } \Sigma x_i \leq 1\}.$$

S^{m-1} is either ∂I^m or $\dot{\Delta}^m$, with their standard PL structures.

In the category of differentiable manifolds D^m is the closed unit disc of \mathbb{R}^m , with centre the origin and standard differentiable structure, while $S^{m-1} = \partial D^m$.

A PL manifold is said to be a PL m -disc if it is PL homeomorphic to D^m . It is a PL m -sphere if it is PL homeomorphic S^m . Analogously a C^∞ manifold is said to be a differentiable m -disc (or differentiable m -sphere) if it is diffeomorphic to D^m (or S^m respectively).

3.7 h -cobordism

We will finish by stating two celebrated results of the topology of manifolds: the h -cobordism theorem and the s -cobordism theorem.

Let $\Gamma = PL$ or Diff. A Γ -cobordism (V, M_0, M_1) is a compact Γ -manifold V , such that ∂V is the disjoint union of M_0 and M_1 . V is said to be an h -cobordism if the inclusions $M_0 \subset V$ and $M_1 \subset V$ are homotopy equivalences.

h -cobordism theorem *If an h -cobordism V is simply connected and $\dim V \geq 6$, then*

$$V \approx_{\Gamma} M_0 \times I,$$

and in particular $M_0 \approx_{\Gamma} M_1$. □

In the case of $\Gamma = \text{Diff}$, the theorem was proved by [Smale 1962]. He introduced the idea of attaching a handle to a manifold and proved the result using a difficult procedure of cancelling handles. Nevertheless, for some technical reasons, the handle theory is better suited to the PL case, while in differential topology the equivalent concept of the Morse function is often preferred. This is, for example, the point of view adopted by [Milnor 1965]. The extension of the theorem to the PL case is due mainly to Stallings and Zeeman. For an exposition see [Rourke and Sanderson, 1972]

The strong PL Poincaré conjecture in $\dim > 5$ follows from the h -cobordism theorem (dimension five also follows but the proof is rather more difficult). The differentiable h -cobordism theorem implies the differentiable Poincaré conjecture, necessarily in the weak version, since the strong version has been disproved by Milnor (the group of differentiable homotopy 7-sphere is $\mathbb{Z}/28$): in other words a differentiable homotopy sphere of $\dim \geq 5$ is a topological sphere.

Weak h -cobordism theorem

(1) *If (V, M_0, M_1) is a PL h -cobordism of dimension five, then*

$$V - M_1 \approx_{\text{PL}} M_0 \times [0, 1).$$

(2) *If (V, M_0, M_1) is a topological h -cobordism of dimension ≥ 5 , then*

$$V - M_1 \approx_{\text{Top}} M_0 \times [0, 1). \quad \square$$

Let $\Gamma = \text{PL}$ or Diff and (V, M_0, M_1) be a connected Γ h -cobordism not necessarily simply connected. There is a well defined element $\tau(V, M_0)$, in the Whitehead group $\text{Wh}(\pi_1(V))$, which is called the *torsion* of the h -cobordism V . The latter is called an *s-cobordism* if $\tau(V, M_0) = 0$.

s -cobordism theorem *If (V, M_0, M_1) is an s -cobordism of $\dim \geq 6$, then*

$$V \approx_{\Gamma} M_0 \times I. \quad \square$$

This result was proved independently by [Barden 1963], [Mazur 1963] and [Stallings 1967] (1963).

Note If A is a free group of finite type then $\text{Wh}(A) = 0$ [Stallings 1965].

4 Uniqueness of the PL structure on \mathbb{R}^m , Poincaré conjecture

In this section we will cover some of the great achievements made by geometric topology during the sixties and, in order to do that, we will need to introduce some more elements of combinatorial topology.

4.1 Stars and links

Recall that *the join* AB of two disjoint simplexes, A and B , in a Euclidean space is the simplex whose vertices are given by the union of the vertices of A and B if those are independent, otherwise the join is undefined. Using joins, we can extend stars and links (defined for vertices in 3.1) to simplexes.

Let A be a simplex of a simplicial complex K , then the *star* and the *link* of A in K are defined as follows:

$$\begin{aligned} S(A, K) &= \{B \in K : A \leq B\} \quad (\text{here } \{, \} \text{ means simplicial closure}) \\ L(A, K) &= \{B \in K : AB \in K\}. \end{aligned}$$

Then $S(A, K) = AL(A, K)$ (join).

If $A = A'A''$, then

$$L(A, K) = L(A', L(A'', K)).$$

From the above formula it follows that a combinatorial manifold K is characterised by the property that for each $A \in K$:

$$L(A, K) \text{ is either a PL sphere or a PL disc.}$$

Furthermore $\partial K \equiv \{A \in K : L(A, K) \text{ is a disc}\}$.

4.2 Alexander's trick

This applies to both PL and Top.

Theorem (Alexander) *A homeomorphism of a disc which fixes the boundary sphere is isotopic to the identity, relative to that sphere.*

Proof It will suffice to prove this result for a simplex Δ . Given $f: \Delta \rightarrow \Delta$, we construct an isotopy $F: \Delta \times I \rightarrow \Delta \times I$ in the following manner:

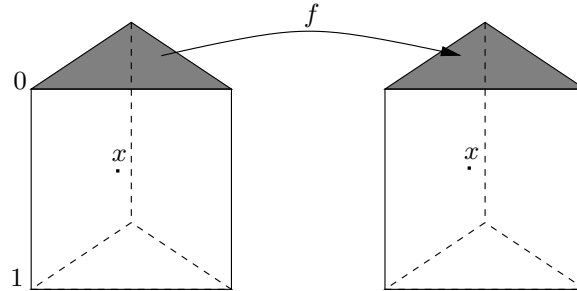

$F|_{\Delta \times \{0\}} = f$; $F = 1$ if restricted to any other face of the prism. In this way we have defined F on the boundary of the prism. In order to extend F to its interior we define $F(x) = x$, where x is the centre of the prism, and then we join conically with $F|\partial$. In this way we obtain the required isotopy. \square

It is also obvious that each homeomorphism of the boundaries of two discs extends conically to the interior.

4.3 Collapses

If $K \supset L$ are two complexes, we say that there is an *elementary simplicial collapse* of K to L if $K - L$ consists of a principal simplex A , together with a free face. More precisely if $A = aB$, then $K = L \cup A$ and $a\dot{B} = L \cap A$

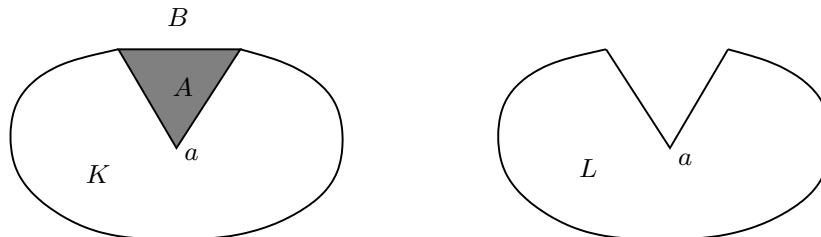

K collapses simplicially to L , written $K \searrow^s L$, if there is a finite sequence of simplicial elementary collapses which transforms K into L .

In other words K collapses to L if there exist simplexes A_1, \dots, A_q of K such that

- (a) $K = L \cup A_1 \cup \dots \cup A_q$
- (b) each A_i has one vertex v_i and one face B_i , such that $A_i = v_i B_i$ and $(L \cup A_1 \cup \dots \cup A_{i-1}) \cap A_i = v_i \dot{B}_i$.

For example, a cone vK collapses to the vertex v and to any subcone.

The definition for polyhedra is entirely analogous. If $X \supset Y$ are two polyhedra we say that there is an *elementary collapse of X into Y* if there exist PL discs D^n and D^{n-1} , with $D^{n-1} \subset \partial D^n$, such that $X = Y \cup D^n$ and, also, $D^{n-1} = Y \cap D^n$

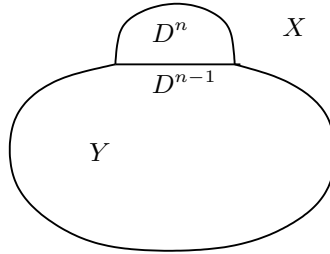

X collapses to Y , written $X \searrow Y$, if there is a finite sequence of elementary collapses which transforms X into Y .

For example, a disc collapses to a point: $D \searrow *$.

Let K and L be triangulations of X and Y respectively and $X \searrow Y$, the reader can prove that there exist subdivisions $K' \triangleleft K$, $L' \triangleleft L$ such that $K' \searrow^s L'$.

Finally, if $K \searrow^s L$, we say that L expands simplicially to K . The technique of collapses and of regular neighbourhoods was invented by JHC Whitehead (1939).

The dunce hat Clearly, if $X \searrow *$, then X is contractible, since each elementary collapse defines a deformation retraction, while the converse is false.

For example, consider the so called dunce hat H , defined as a triangle $v_0v_1v_2$, with the sides identified by the rule $v_0v_1 = v_0v_2 = v_1v_2$.

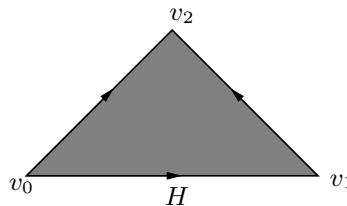

It follows that H is contractible (exercise), but H does not collapse to a point since there are no free faces to start.

It is surprising that $H \times I \searrow *$ [Zeeman, 1964, p. 343].

Zeeman's conjecture If K is a 2-dimensional contractible simplicial complex, then $K \times I \searrow *$.

The conjecture is interesting since it implies a positive answer to the three-dimensional Poincaré conjecture using the following reasoning. Let M^3 be a compact contractible 3-manifold with $\partial M^3 = S^2$. It will suffice to prove that M^3 is a disc. We say that X is a *spine* of M if $M \searrow X$. It is now an easy exercise to prove that M^3 has a 2-dimensional contractible spine K . From the Zeeman conjecture $M^3 \times I \searrow K \times I \searrow *$. PL discs are characterised by the property that they are the only compact PL manifolds that collapse to a point. Therefore $M^3 \times I \approx D^4$ and then $M^3 \subset \dot{D}^4 = S^3$. Since $\partial M^3 \approx S^2$ the manifold M^3 is a disc by the Schoenflies theorem.

For more details see [Glaser 1970, p. 78].

4.4 General position

The *singular set* of a proper map $f: X \rightarrow Y$ of polyhedra is defined as

$$S(f) = \text{closure } \{x \in X : f^{-1}f(x) \neq x\}.$$

Let f be a PL map, then f is *non degenerate* if $f^{-1}(y)$ has dimension 0 for each $y \in f(X)$.

If f is PL, then $S(f)$ is a subpolyhedron.

Let X_0 be a closed subpolyhedron of X^x , with $\overline{X - X_0}$ compact and M^m a PL manifold without boundary, $x \leq m$. Let Y^y be a possibly empty fixed subpolyhedron of M .

A proper continuous map $f: X \rightarrow M$ is said to be *in general position*, relative to X_0 and with respect to Y , if

- (a) f is PL and non degenerate,
- (b) $\dim(S(f) - X_0) \leq 2x - m$,
- (c) $\dim(f(X - X_0) \cap Y) \leq x + y - m$.

Theorem Let $g: X \rightarrow M$ be a proper map such that $g|_{X_0}$ is PL and non degenerate. Given $\varepsilon > 0$, there exists a ε -homotopy of g to f , relative to X_0 , such that f is in general position. \square

For a proof the following reading is advised [Rourke–Sanderson 1972, p. 61].

In terms of triangulations one may think of general position as follows: $f: X \rightarrow M$ is *in general position* if there exists a triangulation (K, K_0) of (X, X_0) such that

- (1) f embeds each simplex of K piecewise linearly into M ,
- (2) if A and B are simplexes of $K - K_0$ then

$$\dim(f(A) \cap f(B)) \leq \dim A + \dim B - m,$$

- (3) if A is a simplex of $K - K_0$ then

$$\dim((f(A) \cap Y) \cap f(X)) \leq \dim A + \dim Y - m.$$

One can also arrange that the following *double-point* condition be satisfied (see [Zeeman 1963]). Let $d = 2x - m$

- (4) $S(f)$ is a subcomplex of K . Moreover, if A is a d -simplex of $S(f) - K_0$, then there is exactly one other d -simplex A_* of $S(f) - K_0$ such that $f(A) = f(A_*)$. If S, S_* are the open stars of A, A_* in K then the restrictions $f|_S, f|_{S_*}$ are embeddings, the images $f(S), f(S_*)$ intersect in $f(\mathring{A}) = f(\mathring{A}_*)$ and contain no other points of $f(X)$.

Remark Note that we have described general position of f both as a map and with respect to the subspace Y , which has been dropped from the notation for the sake of simplicity. We will need a full application of general position later in the proof of Stallings' Engulfing theorem.

Proposition *Let X be compact and let $f: X \rightarrow Z$ be a PL map. Then if $X \supset Y \supset S(f)$ and $X \searrow Y$, then $f(X) \searrow f(Y)$. \square*

The proof is left to the reader. The underlying idea of the proof is clear: $X - Y \not\supset S(f)$, the map f is injective on $X - Y$, therefore each elementary collapse corresponds to an analogous elementary collapse in the image of f .

4.5 Regular neighbourhoods

Let X be a polyhedron contained in a PL manifold M^m . A *regular neighbourhood* of X in M is a polyhedron N such that

- (a) N is a closed neighbourhood of X in M
- (b) N is a PL manifold of dimension m

(c) $N \setminus X$.

We will denote by ∂N the frontier of N in M .

We say that the regular neighbourhood N of X in M meets ∂M transversally if either $N \cap \partial M$ is a regular neighbourhood of $X \cap \partial M$ in ∂M , or $N \cap \partial M = X \cap \partial M = \emptyset$.

The example of a regular neighbourhood par excellence is the following.

Let (K, L) be a triangulation of (M, X) so that each simplex of K meets L in a (possibly empty) face; let $f: K \rightarrow I = \Delta^1$ be the unique simplicial map such that $f^{-1}(0) = L$. Then for each $\varepsilon \in (0, 1)$ it follows that $f^{-1}[0, \varepsilon]$ is a regular neighbourhood of X in M , which meets ∂M transversally:

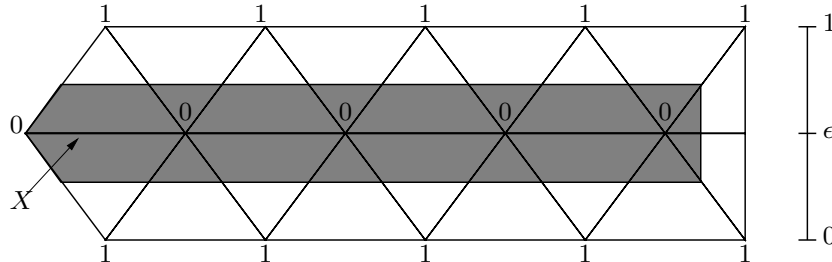

Such a neighbourhood is simply called an ε -neighbourhood.

Theorem *If X is a polyhedron of a PL manifold M^m , then:*

- (1) (Existence) *There always exists a regular neighbourhood of X in M .*
- (2) (Uniqueness up to PL isomorphism) *If N_1, N_2 are regular neighbourhoods of X in M , then there exists a PL isomorphism of N_1 and N_2 , which fixes X .*
- (3) *If $X \searrow *$, then each regular neighbourhood of X is a PL disc.*
- (4) (Uniqueness up to isotopy) *If N_1, N_2 are regular neighbourhoods of X in M , which meet ∂M transversally, then there exists an ambient isotopy which takes N_1 to N_2 and fixes X . □*

For a proof see [Hudson 1969, pp. 57–74] or [Rourke–Sanderson 1972, Chapter 3].

The following properties are an easy consequence of the theorem and therefore are left as an exercise.

- A) *Let N_1, N_2 be regular neighbourhoods of X in M with $N_1 \subset \overset{\circ}{N}_2$. Then if N_1 meets ∂M transversally, there exists a PL homeomorphism*

$$\overline{N_2 - N_1} \approx_{\text{PL}} \partial N_1 \times I.$$

B) **PL annulus theorem** If D_1, D_2 are m -discs with $D_1 \subset \overset{\circ}{D}_2$, then $\overline{D_2 - D_1} \approx_{\text{PL}} \partial D_1 \times I$.

Corollary Let $D_1 \subset \overset{\circ}{D}_2 \subset D_2 \subset \overset{\circ}{D}_3 \subset \dots$ be a chain of PL m -discs. Then

$$\bigcup_1^{\infty} D_i \approx_{\text{PL}} \mathbb{R}^m. \quad \square$$

The statement of the corollary is valid also in the *topological* case: a monotonic union of open m -cells is an m -cell (M Brown 1961).

4.6 Introduction to engulfing

At the start of the Sixties a new powerful geometric technique concerning the topology of manifolds arose and developed thanks to the work of J Stallings and E C Zeeman. It was called *Engulfing* and had many applications, of which the most important were the proofs of the PL weak Poincaré conjecture and of the Hauptvermutung for Euclidean spaces of high dimension.

We say that a subset X —most often a closed subpolyhedron—of a PL m -manifold M may be engulfed by a given open subset U of M if there exists a PL homeomorphism $h: M \rightarrow M$ such that $X \subset h(U)$. Generally h is required to be ambient isotopic to the identity relative to the complement of a compact subset of M .

Stallings and Zeeman compared U to a PL amoeba which expands in M until it swallows X , provided that certain conditions of dimension, of connection and of finiteness are satisfied. This is a good intuitive picture of engulfing in spite of a slight inaccuracy due the fact that U may not be contained in $h(U)$. When X^x is fairly big, ie $x = m - 3$, the amoeba needs lots of help in order to be able to swallow X . This kind of help is offered either by Zeeman's sophisticated *piping* technique or by Stallings' equally sophisticated *covering-and-uncovering* procedure. When X is even bigger, ie $x \geq m - 2$, then the amoeba might have to give up its dinner, as shown by examples constructed using the Whitehead manifolds (1937) and Mazur manifolds (1961). See [Zeeman 1963].

There are many versions of engulfing according to the authors who formalised them and to the specific objectives to which they were turned to. Our primary purpose is to describe the engulfing technique and give all the necessary proofs, with as little jargon as possible and in a way aimed at the quickest achievement of the two highlights mentioned above. At the end of the section the interested reader will find an appendix outlining the main versions of engulfing together with other applications.

We start here with a sketch of one of the highlights—the Hauptvermutung for high-dimensional Euclidean spaces. Full details will be given later. The uniqueness of the PL structure of \mathbb{R}^m for $m \leq 3$ has been proved by Moise (1952), while the uniqueness of the differentiable structure is due to Munkres (1960). J Stallings (1962) proved the PL and Diff uniqueness of \mathbb{R}^m for $m \geq 5$. Stallings’ proof can be summarised as follows: start from a PL manifold, M^m , which is contractible and simply connected at infinity and use engulfing to prove that each compact set $C \subset M$ is contained in an m -cell PL.

Now write M as a countable union $M = \cup_1^\infty C_i$ of compact sets and inductively find m -cells D_i such that \mathring{D}_i engulfs $C_{i-1} \cup D_{i-1}$. Then M is the union $D_1 \subset \mathring{D}_2 \subset D_2 \subset \mathring{D}_3 \subset \dots \subset D_i \subset \mathring{D}_{i+1} \subset \dots$ and it follows from Corollary 4.5 that $M \approx_{\text{PL}} \mathbb{R}^m$. If M has also a C^∞ structure which is compatible with the PL structure, then M is even diffeomorphic to \mathbb{R}^m .

Exercise Show that PL engulfing is not possible, in general, if M has dimension four.

4.7 Engulfing in codimension 3

Zeeman observed that the idea behind an Engulfing Theorem is to convert a homotopical statement into a geometric statement, in other words to pass from Algebra to Geometry.

The fact that X is *homotopic to zero* in the contractible manifold M , ie, that the inclusion $X \subset M$ is homotopic to a constant is a property which concerns the homotopy groups exclusively. The fact that X is contained in a cell of M is a much stronger property of purely geometrical character.

As a first illustration of engulfing we consider a particular case of Stallings’ and Zeeman’s theorems.

Theorem *Let M^m be a contractible PL manifold without boundary, and let X^x be a compact subpolyhedron of M with $x \leq m - 3$. Then X is contained in an m -cell of M .*

We will first prove the theorem for $x < m - 3$. The case $x = m - 3$ is rather more delicate. We will need two lemmas, the first of which is quite general, as it does not use the hypothesis of contractibility on M .

4.7.1 Lemma *Suppose that $X \searrow Y$ and let U be an open subset of M . Then, if Y may be engulfed by U , X too may be engulfed. In particular, if Y is contained in an m -cell of M , then so is X .*

Proof Without loss of generality, assume $Y \subset U$. The idea of the proof is simple: while Y expands to X , it also pulls U with it.

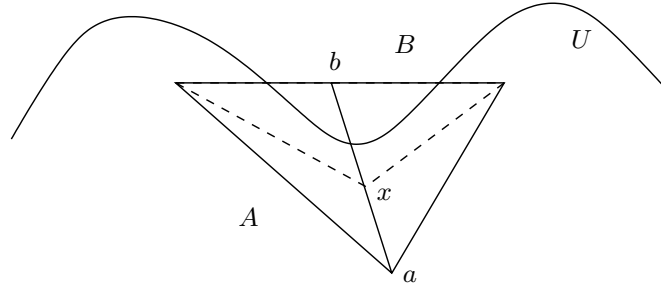

If we take an appropriate triangulation of (M, X, Y) , we can assume that $X \searrow^s Y$. By induction on the number of elementary collapses it will suffice to consider the case when $X \searrow Y$ is an elementary simplicial collapse. Suppose that this collapse happens via the simplex $A = aB$ from the free face B of baricentre b .

Let $L(B, M)$ be the link of B in M , which is a PL sphere so that $bL(B, M)$ is a PL disc D and $S(B, M) = D\dot{B}$. Let $x \in ab$, be such that

$$ax\dot{B} \subset U.$$

There certainly exists a PL homeomorphism $f: D \rightarrow D$ with $f(x) = b$ and $f|_{\dot{D}} = \text{identity}$.

By joining f with $1_{\dot{B}}$, we obtain a PL homeomorphism

$$h: S(B, M) \rightarrow S(B, M)$$

which is the identity on $\dot{S}(B, M)$ and therefore it extends to a PL homeomorphism $h_M: M \rightarrow M$ which takes $ax\dot{B}$ to A . Since

$$U \supset Y \cup ax\dot{B}$$

we will have

$$h_M(U) \supset Y \cup A = X.$$

Since h_M is clearly ambient isotopic to the identity $\text{rel}(M - S(B, M))$, the lemma is proved. \square

4.7.2 Lemma *If M^m is contractible, then there exist subpolyhedra $Y^y, Z^z \subset M$ so that $X \subset Y \searrow Z$ and, furthermore:*

$$\begin{aligned} y &\leq x + 1 \\ z &\leq 2x - m + 3. \end{aligned}$$

Proof Let us consider a cone vX on X . Since X is homotopic to zero in M , we can extend the inclusion $X \subset M$ to a continuous map $f: vX \rightarrow M$. By general position we can make f a PL map fixing the restriction $f|_X$. Then we obtain

$$\dim S(f) \leq 2(x+1) - m.$$

If $vS(f)$ is the subcone of vX , it follows that

$$\dim vS(f) \leq 2x - m + 3.$$

Take $Y = f(vX)$ and $Z = f(vS(f))$.

Since a cone collapses onto a subcone we have

$$vX \searrow vS(f)$$

and, since $vS(f) \supset S(f)$, we deduce that $Y \searrow Z$ by Proposition 4.4. Since $f(X) = X$, it follows that

$$X \subset Y \searrow Z,$$

as required. \square

Proof of theorem 4.7 in the case $x < m - 3$ We will proceed by induction on x , starting with the trivial case $x = -1$ and assuming the theorem true for the dimensions $< x$.

By Lemma 4.7.2 there exist $Y, Z \subset M$ such that

$$X \subset Y \searrow Z$$

and $z \leq 2x - m + 3 < x$ by the hypothesis $x < m - 3$.

Therefore Z is contained in a cell by the inductive hypothesis; by Lemma 4.7.1 the same happens for Y and, a fortiori, for $X \subset Y$. The theorem is proved. \square

▼

Proof of theorem 4.7 in the case $x = m - 3$

This short proof was found by Zeeman in 1966 and communicated to Rourke in a letter [Zeeman, letter 1966].³ The original proofs of Zeeman and Stallings used techniques which are considerably more delicate. We will discuss them in outline in the appendix.

Let f be a map in general position of the cone on X , CX , into M and let $S = S(f) \subset CX$. Consider the projection $p: S \rightarrow X$ (projected down the cone lines of CX). Suppose that everything is triangulated. Then the top

³The letter is reproduced on Colin Rourke's web page at:
<http://www.maths.warwick.ac.uk/~cpr/Zeeman-letter.jpg>

dimensional simplices of $p(S)$ have dimension $x - 1$ and come in pairs τ_1, τ_2 where $\tau_i = p(\sigma_i)$, $\sigma_i \in S$, $i = 1, 2$, with $f(\sigma_1) = f(\sigma_2) = fC(\tau_1) \cap fC(\tau_2)$.

Now let N_i be the union of the open stars of all the τ_i for $i = 1, 2$ and let $X_i = X - N_i$ and $X_0 = X_1 \cap X_2$, ie X minus all the stars. Note that S meets $C(X_0)$ in dimension $\leq x - 2$.

Then $X \subset X \cup f(C(X_2)) \searrow Z = X_1 \cup f(C(X_0))$, by collapsing the cones on the stars of the τ_1 's.

But $Z \subset f(C(X_1)) \searrow fC(X_0)$, by collapsing the cones on the stars of the τ_2 's.

Finally $fC(X_0) \searrow fC(S \cap C(X_0))$ which has dimension $\leq x - 1$ where we have abused notation and written $C(S \cap C(X_0))$ for the union of the cone lines through $S \cap C(X_0)$. We are now in codimension 4 and the earlier proof takes over.

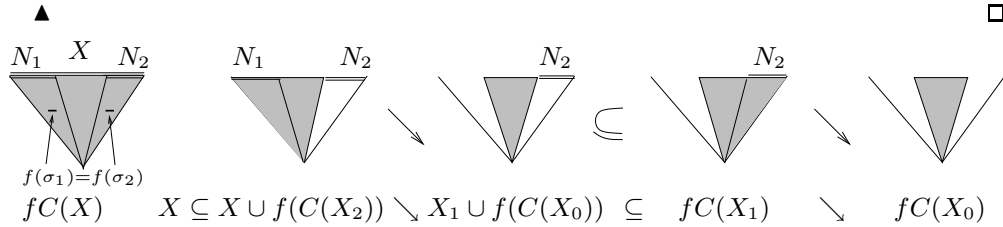

4.8 Hauptvermuting for \mathbb{R}^m and the weak Poincaré conjecture

A topological space X is *simply connected* (or *1-connected*) *at infinity* if, for each compact subset C of X , there exists a compact set C_1 such that $C \subset C_1 \subset X$ and, furthermore, $X - C_1$ is simply connected.

For example, \mathbb{R}^m , with $m > 2$, is 1-connected at infinity, while \mathbb{R}^2 is not.

Observation *Let X be 2-connected and 1-connected at infinity. Then for each compact set $C \subset M$ there exists a compact set C_1 such that $C \subset C_1 \subset M$ and, furthermore, $(X, X - C_1)$ is 2-connected.*

Apply the homotopy exact sequence to the pair $(X, X - C_1)$ with $C_1 \supset C$ so that $X - C_1$ is 1-connected. □

Stallings' Engulfing Theorem *Let M^m be a PL manifold without boundary and let U be an open set of M . Let X^x be a closed subpolyhedron of M , such that*

- (a) (M, U) is x -connected,
- (b) $X \cap (M - U)$ is compact,
- (c) $x \leq m - 3$.

Then there exist a compact set $G \subset M$ and a PL homeomorphism $h: M \rightarrow M$, such that

- (1) $X \subset h(U)$,
- (2) h is ambient isotopic to the identity rel $M - G$

Proof Write X as $X_0 \cup Y$ where $X_0 \subset U$ and Y is compact. We argue by induction on the dimension y of Y . The induction starts with $y = -1$ when there is nothing to prove. For the induction step there are two cases.

Case of codim ≥ 4 ie, $y \leq m - 4$

Denote by $Y \times' I$ the result of squeezing $(X_0 \cap Y) \times I$ to $X_0 \cap Y$ fibrewise in $Y \times I$. For $i = 0, 1$, continue to write $Y \times i$ for the image of $Y \times i$ under the projection $Y \times I \rightarrow Y \times' I$.

Since $y \leq x$, by hypothesis (a) there is a map $f: Y \times' I \rightarrow M$ such that $f|_{Y \times 0} = \text{id}$ and $f(Y \times 1) \subset U$. Put f in general position both as a map and with respect to X . Let $\Sigma \subset Y \times' I$ be the preimage of the singular set, which includes the points where the image intersects X_0 . Define the *shadow* of Σ , denoted $\text{Sh}(\Sigma)$, to be $\{(y, t) \mid (y, s) \in \Sigma \text{ some } s\}$. Then since Σ has codim at least 3 in $Y \times' I$, $\text{Sh}(\Sigma)$ has codim at least 2 in $Y \times' I$, ie $\dim \leq y - 1$.

Now write $X'_0 = X_0 \cup f(Y \times 1)$ and $Y' = f(\text{Sh}(\Sigma))$ and $X' = X'_0 \cup Y'$, then we have $\dim(Y') < y$ and

$$X \subset X'' = X \cup f(Y \times' I) \searrow X'$$

where the collapse is induced by cylindrical collapse of $Y \times' I - \text{Sh}(\Sigma)$ from $Y \times 0$ which is embedded by f . But by induction X' can be engulfed and hence by lemma 4.7.1 so can X'' and hence X .

It remains to remark that the engulfing moves are induced by a finite collapse and hence are supported in a compact set G as required.

▼

Case of codim 3 ie, $y = m - 3$

The proof is similar to the proof of theorem 4.7 in the codim 3 case.

Let f and Σ be as in the last case and consider the projection $p: Y \times' I \rightarrow Y$. Suppose that everything is triangulated so that X is a subcomplex and f and p are simplicial. Then the top dimensional simplexes of $p(\Sigma)$ have dimension $y - 1$ and come in pairs τ_1, τ_2 where $\tau_i = p(\sigma_i)$, $\sigma_i \in \Sigma$, $i = 1, 2$, with $f(\sigma_1) = f(\sigma_2) = f(\tau_1 \times I) \cap f(\tau_2 \times I)$.

Now let N_i be the union of the open stars of all the τ_i for $i = 1, 2$ and let $Y_i = Y - N_i$ and $Y_0 = Y_1 \cap Y_2$, ie Y minus all the stars. Note that Σ meets $Y_0 \times' I$ in dimension $\leq y - 2$.

Then $X \subset X \cup f(Y_2 \times' I \cup Y \times 1) \searrow Z = X_0 \cup f(Y_0 \times' I \cup Y_1 \cup Y \times 1)$, by cylindrically collapsing the cylinders over the stars of the τ_1 's from the 0-end. But

$$Z \subset X_0 \cup f(Y_1 \times' I \cup Y \times 1) \searrow T = X_0 \cup f(Y_0 \times' I \cup Y \times 1)$$

by similarly collapsing the $\tau_2 \times I$'s. Finally let $Y' = \text{Sh}(\Sigma) \cap Y_0 \times' I$ which has dimension $< y$ and let $X'_0 = X_0 \cup f(Y \times 1)$ and $X' = X'_0 \cup Y'$. Then $T \searrow X'$ by cylindrically collapsing $Y_0 \times' I - \text{Sh}(\Sigma)$.

But X' can be engulfed by induction, hence so can T and hence Z and hence X .

▲

□

4.8.1 Note If we apply the theorem with X compact, M contractible and U an open m -cell, we reobtain Theorem 4.7 above.

The following corollary is of crucial importance.

4.8.2 Corollary *Let M^m be a contractible PL manifold, 1-connected at infinity and $C \subset M$ a compact set. Let T be a triangulation of M , and T^2 its 2-skeleton, $m \geq 5$. Then there exists a compact set $G_1 \supset C$ and a PL homeomorphism $h_1: M \rightarrow M$, such that*

$$T^2 \subset h_1(M - C) \quad \text{and} \quad h_1 \text{ fixes } M - G_1.$$

Proof By Observation 4.8 there exists a compact set C_1 , with $C \subset C_1 \subset M$ and $(M, M - C_1)$ 2-connected. We apply the Engulfing Theorem with $U = M - C_1$ and $X = T^2$. The result follows if we take $h_1 = h$ and $G_1 = G \cup C$. The condition $m \geq 5$ ensures that $2 = x \leq m - 3$. □

Note Since $h_1(M) = M$, it follows that $h_1(C) \cap T^2 = \emptyset$. In other words there is a deformation of M so that the 2-skeleton avoids C .

Theorem (PL uniqueness for \mathbb{R}^m) *Let M^m be a contractible PL manifold which is 1-connected at infinity and with $m \geq 5$. Then*

$$M^m \approx_{\text{PL}} \mathbb{R}^m.$$

Proof By the discussion in 4.6 it suffices to show that each compact subset of M is contained in an m -cell in M . So let $C \subset M$ be a compact set and T a triangulation of M . First we apply Corollary 4.8.2 to T . Now let $K \subset T$ be the subcomplex

$$K = T^2 \cup \{\text{simplexes of } T \text{ contained in } M - G_1\}.$$

Since $T^2 \subset h_1(M - C)$ and h_1 fixes $M - G_1$, then necessarily

$$K \subset h_1(M - C).$$

Now, if Y is a subcomplex of the simplicial complex X , the *complementary complex* of Y in X , denoted $X \div Y$ by Stallings, is defined as the subcomplex of the barycentric subdivision X' of X which is maximal with respect to the property of not intersecting Y . If Y contains all the vertices of X , then regular neighbourhoods of the two complexes Y and $X \div Y$ cover X . Indeed the $\frac{1}{2}$ -neighbourhoods of Y and $X \div Y$ have a common frontier since the 1-simplexes of X' have some vertices in X and the rest in $X \div Y$.

Let $L = T \div K$. Then L is a compact polyhedron of dimension $\leq m - 3$. By Theorem 4.7, or Note 4.8.1, L is contained in an m -cell. Since $K \subset h_1(M - C) \subset M - h_1(C)$, we have $h_1(C) \cap K = \emptyset$, therefore there exists a ε -neighbourhood, N_ε , of L in M such that

$$h_1(C) \subset N_\varepsilon \searrow L.$$

By Lemma 4.7.1 N_ε , and therefore $h_1(C)$, is contained in an m -cell $\overset{\circ}{D}$. But then $h_1^{-1}(\overset{\circ}{D})$ is an m -cell which contains C , as we wanted to prove. \square

Corollary (Weak Poincaré conjecture) *Let M^m be a closed PL manifold homotopically equivalent to S^m , with $m \geq 5$. Then*

$$M^m \approx_{\text{Top}} S^m.$$

Proof If $*$ is a point of M , an argument of Algebraic Topology establishes that $M \setminus *$ is contractible and simply connected at infinity. Therefore M is topologically equivalent to the compactification of \mathbb{R}^m with one point, ie to an m -sphere. \square

4.9 The differentiable case

The reader is reminded that each differentiable manifold admits a unique PL manifold structure which is compatible [Whitehead 1940]. We will prove this theorem in the following sections. We also know that two differentiable structures on \mathbb{R}^m are diffeomorphic if they are PL homeomorphic [Munkres 1960].

The following theorem follows from these facts and from what we proved for PL manifolds.

Theorem *Let M^m be a differentiable manifold contractible and 1-connected at infinity. Then if $m \geq 5$,*

$$M^m \approx_{\text{Diff}} \mathbb{R}^m. \quad \square$$

Corollary (C^∞ uniqueness for \mathbb{R}^m) *If $m \geq 5$, \mathbb{R}^m admits a unique differentiable structure.* \square

4.10 Remarks

These are wonderful and amazingly powerful theorems, especially so considering the simple tools which formed the basis of the techniques used. It is worth recalling that combinatorial topology was revived from obscurity at the beginning of the Sixties. When, later on, in a much wider, more powerful and sophisticated context, we will reprove that a Euclidean space E , of dimension ≥ 5 , admits a unique PL or Diff structure simply because, E being contractible, each bundle over E is trivial, some readers might want to look again at these pages and these pioneers, with due admiration.

4.11 Engulfing in a topological product

We finish this section (apart from the appendix) with a simple engulfing theorem, whose proof does not appear in the literature, which will be used to establish the important fibration theorem III.1.7.

4.11.1 Theorem *Let W^w be a closed topological manifold with $w \neq 3$, let Θ be a PL structure on $W \times \mathbb{R}$ and $C \subset W \times \mathbb{R}$ a compact subset. Then there exists a PL isotopy G of $(W \times \mathbb{R})_\Theta$ having compact support and such that $G_1(C) \subset W \times (-\infty, 0]$.*

▼

Proof For $w = 2$ the 3-dimensional Hauptvermutung of Moise implies that $(W \times \mathbb{R})_\Theta$ is PL isomorphic to $W \times \mathbb{R}$, where W is a surface with its unique PL structure. Therefore the result is clear.

Let now $Q = (W \times \mathbb{R})_\Theta$ and $\dim Q \geq 5$. If (a, b) is an interval in \mathbb{R} we write $Q_{(a,b)}$ for $W \times (a, b)$. Let U be the open set $Q_{(-\infty, 0)}$ and assume that C is contained in $Q_{(-r, r)}$. Write V for the open set $Q_{(r, \infty)}$ so that $V \cap C = \emptyset$. We want to engulf C into U .

Let T be a triangulation of Q by small simplexes, and let K be the smallest subcomplex containing a neighbourhood of $Q_{[-r, 2r]}$. Let K^2 be the 2-skeleton and L be the complementary complex in K . Then L has codimension three. Now consider $V_0 = Q_{(r, 2r)}$ in $Q_0 = Q_{(-\infty, 2r)}$ and let $L_0 = L \cap Q_0$. The

pair (Q_0, V_0) is ∞ -connected. Therefore, by Stallings' engulfing theorem, there exists a PL homeomorphism $j: Q_0 \rightarrow Q_0$ such that

- (a) $L_0 \subset j(V_0)$
- (b) there is an isotopy of j to the identity, which is supported by a compact set.

It follows from (b) that j is fixed near level $2r$ and hence extends by the identity to a homeomorphism of Q to itself such that $j(V) \supset L \cup Q_{[2r, \infty]}$.

In exactly the same way there is a PL homeomorphism $h: Q \rightarrow Q$ such that $h(U) \supset K^2 \cup Q_{[-\infty, -r]}$. Now $h(U)$ and $j(V)$ contain all of Q outside K and also neighbourhoods of complementary complexes of the first derived of K . By stretching one of these neighbourhoods we can assume that they cover K . Hence we can assume $h(U) \cup j(V) = Q$. Then $j^{-1} \circ h(U) \cup V = Q$ and it follows that $j^{-1} \circ h(U) \supset C$. But each of j^{-1} , h is isotopic to the identity with compact support. Hence there is an isotopy G with compact support finishing with $G_1 = j^{-1} \circ h$ and $G_1(C) \subset U$.

▲

□

Remark If W is compact with boundary the same engulfing theorem holds, provided $C \cap \partial W \subset U$.

4.12 Appendix: other versions of engulfing

This appendix, included for completeness and historical interest, discusses other versions of engulfing and their main applications.

▼

Engulfing à la Zeeman

Instead of Stallings' engulfing *by* or *into* an open subset, Zeeman considers engulfing *from* a closed subpolyhedron of the ambient manifold M .

Precisely, given a closed subpolyhedron C of M , we say that X *may be engulfed from* C if X is contained in a regular neighbourhood of C in M .

Theorem (Zeeman) *Let X^x , C^c be subpolyhedra of the compact manifold M , with C closed and X compact, $X \subset \overset{\circ}{M}$, and suppose the following conditions are met:*

- (i) (M, C) is k -connected, $k \geq 0$
- (ii) there exists a homotopy of X into C which is modulo C
- (iii) $x \leq m - 3$; $c \leq m - 3$; $c + x \leq m + k - 2$; $2x \leq m + k - 2$

Then X may be engulfed from C

□

Zeeman considers also the cases in which X meets or is completely contained in the boundary of M but we do not state them here and refer the reader to [Zeeman 1963]. The above theorem is probably the most accurate engulfing theorem, in the sense that examples show that its hypotheses cannot be weakened. Thus no significant improvements are possible except, perhaps, for some comments regarding the boundary.

Piping This was invented by Zeeman to prove his engulfing Theorem in codimension three, which enabled him to improve the Poincaré conjecture from the case $n \geq 7$ to the case $n \geq 5$.

A rigorous treatment of the piping construction—not including the preliminary parts—occupies about twenty-five pages of [Zeeman 1963]. Here I will just try to explain the gist of it in an intuitive way, using the terminology of isotopies rather than the more common language of collapsing. As we saw earlier, Zeeman [Letter 1966] found a short proof avoiding this rather delicate construction.

Instead of seeing a ball which expands to engulf X , change your reference system and think of a (magnetized) ball U by which X is homotopically attracted. Let f be the appropriate homotopy. On its way towards U , X will bump into lots of obstacles represented by polyhedra of varying dimensions, that cause X to step backward, curl up and take a different route. This behaviour is encoded by the singular set $S(f)$ of f . Consider the union $T(f)$ of the shadow-lines leading to these singularities.

If $x < m - 3$, then $\dim T(f) < x$. Thus, by induction, $T(f)$ may be engulfed into U . Once this has been done, it is not difficult to view the remaining part of the homotopy as an isotopy f' which takes X into U . Then any ambient isotopy covering f' performs the required engulfing.

If $x = m - 3$, $\dim T(f)$ may be equal to $\dim X$ so that we cannot appeal to induction. Now comes the piping technique. By general position we may obtain that $T(f)$ meets the relevant obstructing polyhedron at single points. Zeeman's procedure consists of piping away these points so as to reduce to the previous easier case. The difficulty lies in the fact that the intersection-points to be eliminated are *essential*, in the sense that they cannot be removed by a local shift. On the contrary, the whole map f needs to be altered, and in a way such that the part of X which is already covered by U be not uncovered during the alteration.

Here is the germ of the construction.

Work in the homotopy cylinder on which f is defined. Let z be a *bad* point, ie, a point of $T(f)$ that gives rise to an intersection which we want to eliminate. Once general position has been fully exploited, we may assume—to fix ideas—that

- (a) z lies above the barycenter a_1 of a top-dimensional simplex $A_1 \in S(f)$ such that there is exactly one other simplex A_2 with $f(\overset{\circ}{A}_1) = f(\overset{\circ}{A}_2)$; moreover f is non degenerate and $f(a_1) = f(a_2)$.

(b) no bad points lie above the barycenter a_2 .

Run a thin pipe from the top of the cylinder so as to pierce a hole around the barycenter a_2 . More precisely, take a small regular neighbourhood N of the union with $X \times I$ with the shadow-line starting at a_2 . Then consider the closure V of $X \times [0, 1] - N$ in $X \times [0, 1]$. Clearly V is a collar on $X \times 0$. Identify V with $X \times [0, 1]$ by a vertical stretch. This produces a new homotopy \bar{f} which takes X off the obstructing polyhedron. Now note that z is still there, but, thanks to the pipe, it has magically ceased to be a bad point. In fact a_1 is not in $S(\bar{f})$ because its brother a_2 has been removed by the pipe, so z does not belong to the shadow-lines leading to $S(\bar{f})$ and the easier case takes over.

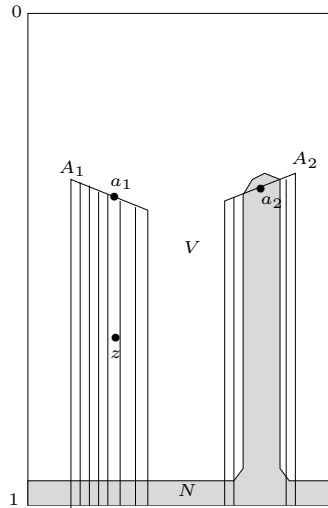

We have skated over many things: one or both of A_1 , A_2 could belong to $X \times 0$, A_2 could be a vertical simplex, in general there will be many pipes to be constructed simultaneously, et cetera. But these constitute technical complications which can be dealt with and the core of the piping argument is the one described above.

The original proof of Stallings did not use piping but a careful inductive collapsing procedure which has the following subtle implication: when the open set U tries to expand to finally engulf the interior of the $m - 3$ simplex of X , it is forced to *uncover* the interior of some superfluous $(m - 2)$ -simplexes of M which had been previously covered.

To sum up, while in codimension > 3 one is able to engulf more than it is necessary, in the critical codimension one can barely engulf just what is necessary, and only after a lot of padding has been eliminated.

Engulfing à la Bing or Radial Engulfing

Sometimes one wants that the engulfing isotopy moves each point of X along a *prescribed direction*.

Theorem (Bing) *Let $\{A_\alpha\}$ be a collection of sets in a boundariless PL manifold M^m , let $X^x \subset M$ be a closed subpolyhedron, $x \leq m - 4$, U an open subset of M with $X \cap (M - U)$ compact. Suppose that for each compact y -dimensional polyhedron Y , $y \leq x$, there exists a homotopy F of Y into U such that, for each point $y \in Y$, $F(y \times [0, 1])$ lies in one element of $\{A_\alpha\}$.*

Then, for each $\varepsilon > 0$, there is an ambient engulfing isotopy H of M satisfying the condition that, for each point $p \in M$, there are $x + 1$ elements of $\{A_\alpha\}$ such that the track $H(p \times [0, 1])$ lies in an ε -neighbourhood of the union of these $x + 1$ elements. \square

For a proof see [Bing 1967].

There is also a Radial Engulfing Theorem for the codimension three, but it is more complicated and we omit it [Bing op. cit.].

Engulfing by handle-moves

This idea is due to [Rourke–Sanderson 1972]. It does not lead to a different engulfing theorem, but rather to an alternative method for proving the classical engulfing theorems. The approach consists of using the basic constructions of Smale's handle-theory (originally aimed at the proof of the h -cobordism theorem), namely the elementary handle-moves, in order to engulf a given subpolyhedron of a PL manifold. Consequently it is an easy guess that the language of cobordism turns out to be the most appropriate here.

Given a compact PL cobordism (V^v, M_0, M_1) , and a compact subpolyhedron X of W , we say that X may be engulfed from the end M_0 of V if X is contained in a collar of M_0 .

Theorem *Assume $X \cap M_1 = \emptyset$, and suppose that the following conditions are met:*

- (i) *there is a homotopy of X into a collar of M_0 relative to $X \cap M_0$*
- (ii) *(V, M_0) is k -connected*
- (iii) *$2x \leq v + k - 2$ and $x \leq v - 3$*

Then X may be engulfed from M_0 \square

It could be shown that the main engulfing theorems previously stated, including radial engulfing, may be obtained using handle-moves, with tiny improvements here and there, but this is hardly worth our time here.

Topological engulfing

This was worked out by M Newman (1966) in order to prove the topological Poincaré conjecture. E Connell (1967) also proved topological engulfing independently, using PL techniques, and applied it to establish the weak topological h -cobordism theorem.

The statement of Newman's theorem is completely analogous to Stallings' engulfing, once some basic notions have been extended from the PL to the topological context. We keep the notations of Stallings' theorem. The concept of p -connectivity for (M, U) must be replaced by that of monotonic connectivity. The pair (M, U) is *monotonically p -connected*, if, given any compact subset C of U , there exists a closed subset D of U containing C and such that $(M - D, U - D)$ is p -connected.

Assume that X is a polyhedron contained in the topological boundaryless manifold M . We say that X is *tame* in M if around each point x of X there is a chart to \mathbb{R}^m whose restriction to X is PL.

Theorem *If (M, U) is monotonically x -connected and X is tame in M , then there is an ambient compactly supported topological isotopy which engulfs X into U .* \square

See [Newman 1966] and [Connell 1967].

Applications

We conclude this appendix by giving a short list of the main applications of engulfing.

- The Hauptvermutung for \mathbb{R}^m ($n \geq 5$) (Theorem 4.8) (Stallings' or Zeeman's engulfing)
- Weak PL Poincaré conjecture for $n \geq 5$ (Corollary 4.8) (Stallings' or Zeeman's engulfing)
- Topological Poincaré conjecture for $n \geq 5$ (Newman's engulfing)
- Weak PL h -cobordism theorem for $n \geq 5$ (Stallings' engulfing)
- Weak topological h -cobordism theorem for $n \geq 5$ (Newman's or Connell's engulfing)
- Any stable homeomorphism of \mathbb{R}^m can be ε -approximated by a PL homeomorphism (Radial engulfing)
- (Irwin's embedding theorem) Let $f: M^m \rightarrow Q^q$ be a map of unbounded PL manifolds with M compact, and assume that the following conditions are met:
 - (i) $q - m \geq 3$
 - (ii) M is $(2m - q)$ -connected
 - (iii) Q is $(2m - q + 1)$ -connected

Then f is homotopic to a PL embedding. \square

In particular:

- (a) any element of $\pi_m(Q)$ may be represented by an embedding of an m -sphere
- (b) a closed k -connected m -manifold embeds in \mathbb{R}^{2m-k} , provided $m - k \geq 3$.

The theorem may be proved using Zeeman's engulfing

See [Irwin 1965], and also [Zeeman 1963] and [Rourke-Sanderson 1972].

▲

Part II : Microbundles

1 Semisimplicial sets

The construction of simplicial homology and singular homology of a simplicial complex or a topological space is based on a simple combinatorial idea, that of incidence or equivalently of face operator.

In the context of singular homology, a new operator was soon considered, namely the degeneracy operator, which locates all of those simplices which factorise through the projection onto one face. Those were, rightly, called degenerate simplices and the guess that such simplices should not contribute to homology turned out to be by no means trivial to check.

Semisimplicial complexes, later called semisimplicial sets, arose round about 1950 as an abstraction of the combinatorial scheme which we have just referred to (Eilenberg and Zilber 1950, Kan 1953). Kan in particular showed that there exists a homotopy theory in the semisimplicial category, which encapsulates the combinatorial aspects of the homotopy of topological spaces [Kan 1955].

Furthermore, the semisimplicial sets, despite being purely algebraically defined objects, contain in their DNA an intrinsic topology which proves to be extremely useful and transparent in the study of some particular function spaces upon which there is not given, it is not desired to give or it is not possible to give in a straightforward way, a topology corresponding to the posed problem. Thus, for example, while the space of loops on an ordered simplicial complex is not a simplicial complex, it can nevertheless be defined in a canonical way as a semisimplicial set.

The most complete bibliographical reference to the study of semisimplicial objects is [May 1967]; we also recommend [Moore 1958] for its conciseness and clarity.

1.1 The semisimplicial category

Recall that the standard simplex $\Delta^m \subset \mathbb{R}^m$ is

$$\Delta^m = \{(x_1, \dots, x_m) \in \mathbb{R}^m : x_i \geq 0 \text{ and } \Sigma x_i \leq 1\}.$$

The vertices of Δ^m are ordered $0, e_1, e_2, \dots, e_m$, where e_i is the unit vector in the i^{th} coordinate. Let Δ^* be the category whose objects are the standard

simplices $\Delta^k \subset \mathbb{R}^k$ ($k = 0, 1, 2, \dots$) and whose morphisms are the simplicial monotone maps $\lambda: \Delta^j \rightarrow \Delta^k$. A *semisimplicial object* in a category \mathcal{C} is a contravariant functor

$$X: \Delta^* \rightarrow \mathcal{C}.$$

If \mathcal{C} is the category of sets, X is called a *semisimplicial set*. If \mathcal{C} is the category of monoids (or groups), X is called a *semisimplicial monoid* (or *group*, respectively).

We will focus, for the moment, on semisimplicial sets, abbreviated SS-sets.

We write $X^{(k)}$ instead of $X(\Delta^k)$ and call $X^{(k)}$ the *set of k -simplices of X* . The morphism induced by λ will be denoted by $\lambda^\#: X^{(k)} \rightarrow X^{(j)}$. A simplex of X is called *degenerate* if it is of the form $\lambda^\#\tau$, with λ *non* injective; if, on the contrary, λ is injective, $\lambda^\#\tau$ is said to be a *face* of τ .

A simplicial complex K is said to be *ordered* if a partial order is given on its vertices, which induces a total order on the vertices of each simplex in K . In this case K determines an SS-set \mathbf{K} defined as follows:

$$\mathbf{K}^{(n)} = \{f: \Delta^n \rightarrow K : f \text{ is a simplicial monotone map}\}.$$

If $\lambda \in \Delta^*$, then $\lambda^\#f$ is defined as $f \circ \lambda$. In particular, if Δ^k is a standard simplex, it determines an SS-set $\mathbf{\Delta}^k$.

The most important example of an SS-set is the *singular complex*, $\text{Sing}(A)$, of a topological space A . A k -simplex of $\text{Sing}(A)$ is a map $f: \Delta^k \rightarrow A$ and, if $\lambda: \Delta^j \rightarrow \Delta^k$ is in Δ^* , then $\lambda^\#(f) = f \circ \lambda$.

We notice that, if A is a one-point set $*$, each simplex of dimension > 0 in $\text{Sing}(*)$ is degenerate.

If X, Y are SS-sets, a *semisimplicial map* $f: X \rightarrow Y$, (abbreviated to *SS-map*), is a natural transformation of functors from X to Y . Therefore, for each k , we have maps $f^{(k)}: X^{(k)} \rightarrow Y^{(k)}$ which make the following diagrams commute

$$\begin{array}{ccc} X^{(k)} & \xrightarrow{f^{(k)}} & Y^{(k)} \\ \lambda^\# \downarrow & & \downarrow \lambda^\# \\ X^{(j)} & \xrightarrow{f^{(j)}} & Y^{(j)} \end{array}$$

for each $\lambda: \Delta^j \rightarrow \Delta^k$ in Δ^* .

Examples

- (a) A map $g: A \rightarrow B$ induces an ss-map $\text{Sing}(A) \rightarrow \text{Sing}(B)$ by composition.
- (b) If X is an ss-set, a k -simplex τ of X determines a *characteristic map* $\tau: \Delta^k \rightarrow X$ defined by setting

$$\tau(\mu) := \mu^\#(\tau).$$

The composition of two ss-maps is again an ss-map. Therefore we can define the *semisimplicial category* (denoted by **SS**) of semisimplicial sets and maps. Finally, there are obvious notions of *sub ss-set* $A \subseteq X$ and *pair* (X, A) of ss-sets.

1.2 Semisimplicial operators

In order to have a concrete understanding of the category **SS** we will examine in more detail the category Δ^* .

Each morphism of Δ^* is a composition of morphisms of two distinct types:

- (a) $\sigma_i: \Delta^m \rightarrow \Delta^{m-1}$, $0 \leq i \leq m - 1$,
 $\sigma_0(t_1, \dots, t_m) = (t_2, \dots, t_m)$
 $\sigma_i(t_1, \dots, t_m) = (t_1, \dots, t_{i-1}, t_i + t_{i+1}, t_{i+2}, \dots, t_m)$ for $i > 0$
- (b) $\delta_i: \Delta^m \rightarrow \Delta^{m+1}$, $0 \leq i \leq m + 1$,
 $\delta_0(t_1, \dots, t_m) = (1 - \sum_1^m t_i, t_1, \dots, t_m)$.
 $\delta_i(t_1, \dots, t_m) = (t_1, \dots, t_{i-1}, 0, t_i, \dots, t_m)$ for $i > 0$.

The morphism σ_i flattens the simplex on the face opposite the vertex v_i , preserving the order.

Example

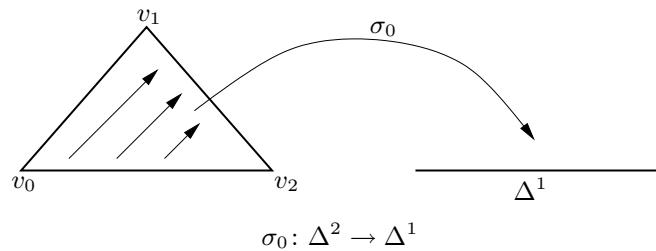

The morphism δ_i embeds the simplex into the face opposite to the vertex v_i .

Example

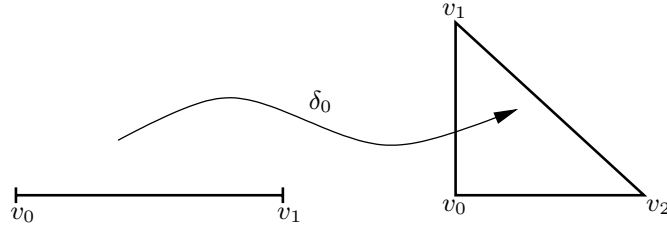

The following relations hold:

$$\begin{aligned} \delta_j \delta_i &= \delta_i \delta_{j-1} & i < j \\ \sigma_j \sigma_i &= \sigma_i \sigma_{j+1} & i \leq j \\ \sigma_j \delta_i &= \delta_i \sigma_{j-1} & i < j \\ \sigma_j \delta_j &= \sigma_j \delta_{j+1} = 1 \\ \sigma_j \delta_i &= \delta_{i-1} \sigma_j & i > j + 1 \end{aligned}$$

If $\lambda \in \Delta^*$ is injective, then λ is a composition of morphisms of type δ_i , otherwise λ is a composition of morphisms σ_i and morphisms δ_j . Therefore, if X is an SS-set and if we denote $\sigma_i^\#$ by s_i and $\delta_j^\#$ by ∂_j , we get a description of X as a sequence of sets

$$X^0 \begin{array}{c} \leftarrow \\ \leftarrow \\ \leftarrow \\ \rightarrow \\ \rightarrow \\ \rightarrow \end{array} X^1 \begin{array}{c} \leftarrow \\ \leftarrow \\ \leftarrow \\ \rightarrow \\ \rightarrow \\ \rightarrow \end{array} X^2 \begin{array}{c} \leftarrow \\ \leftarrow \\ \leftarrow \\ \rightarrow \\ \rightarrow \\ \rightarrow \end{array} X^3$$

where the arrows pointing left are the face operators ∂_j and the remaining arrows are the degeneracy operators s_i . Obviously, we require the following relations to hold:

$$\begin{aligned} \partial_i \partial_j &= \partial_{j-1} \partial_i & i < j \\ s_i s_j &= s_{j+1} s_i & i \leq j \\ \partial_j s_j &= \partial_{j+1} s_j = 1 \\ \partial_i s_j &= s_{j-1} \partial_i & i < j \\ \partial_i s_j &= s_j \partial_{i-1} & i > j + 1 \end{aligned}$$

In the case of the singular complex $\text{Sing}(A)$, the map ∂_i is the usual face operator, ie, if $f: \Delta^k \rightarrow A$ is a k -singular simplex in A , then $\partial_i f$ is the $(k-1)$ -singular simplex in A obtained by restricting f to the i -th face of Δ^k :

$$\partial_i f: \Delta^{k-1} \xrightarrow{\delta_i} \Delta^k \xrightarrow{f} A.$$

On the other hand, $s_j f$ is the $(k+1)$ -singular simplex in A obtained by projecting Δ^{k+1} on the j -th face and then applying f :

$$s_j f: \Delta^{k+1} \xrightarrow{\sigma_j} \Delta^k \xrightarrow{f} A.$$

The following lemma is easy to check and the theorem is a corollary.

Lemma (Unique decomposition of the morphisms of Δ^*) *If φ is a morphism of Δ^* , then φ can be written, in a unique way, as*

$$\varphi = \underbrace{(\delta_{i_1} \circ \delta_{i_2} \circ \cdots \circ \delta_{i_p})}_{\text{injective}} \circ \underbrace{(s_{j_1} \circ \cdots \circ s_{j_t})}_{\text{surjective}} = \varphi_1 \circ \varphi_2. \quad \square$$

Theorem (Eilenberg–Zilber) *If X is an ss-set and θ is an n -simplex in X , then there exist a unique non-degenerate simplex τ and a unique surjective morphism $\mu \in \Delta^*$, such that*

$$\mu^*(\tau) = \theta. \quad \square$$

1.3 Homotopy

If X, Y are ss-sets, their *product*, $X \times Y$, is defined as follows:

$$\begin{aligned} (X \times Y)^{(k)} &:= X^{(k)} \times Y^{(k)} \\ \lambda^\#(x, y) &:= (\lambda^\#x, \lambda^\#y) \end{aligned}$$

Example $\text{Sing}(A \times B) \approx \text{Sing}(A) \times \text{Sing}(B)$.

Let us write $I = \Delta^1$, $\mathbf{I} = \mathbf{\Delta}^1$. Then \mathbf{I} has three non-degenerate simplices, ie $0, 1, I$, or, more precisely, $\Delta^0 \rightarrow 0$, $\Delta^0 \rightarrow 1$, $\Delta^1 \rightarrow I$. Write $\mathbf{0}$ for the ss-set obtained by adding to the simplex 0 all of its degeneracies, corresponding to the simplicial maps

$$\Delta^k \rightarrow 0, \quad (1.3.1)$$

$k = 1, 2, \dots$. Hence, $\mathbf{0}$ has a k -simplex in each dimension. For $k > 0$, the k -simplex is degenerate and it consists of the singular simplex (1.3.1).

Proceed in a similar manner for $\mathbf{1}$. One could also say, more concisely,

$$\mathbf{0} = \text{Sing}(0) \quad \mathbf{1} = \text{Sing}(1).$$

Now, let $f_0, f_1: X \rightarrow Y$ be two semisimplicial maps.

A *homotopy* between f_0 and f_1 is a semisimplicial map

$$F: \mathbf{I} \times X \rightarrow Y$$

such that $F|\mathbf{0} \times X = f_0$ and $F|\mathbf{1} \times X = f_1$ through the canonical isomorphisms $\mathbf{0} \times X \approx X \approx \mathbf{1} \times X$.

In this case, we say that f_0 is *homotopic* to f_1 , and write $f_0 \simeq f_1$. Unfortunately homotopy is *not* an equivalence relation. Let us look at the simplest

situation: $X = \Delta^0$. Suppose we have two homotopies $F, G: \mathbf{I} \rightarrow Y$, with $F(\mathbf{1}) = G(\mathbf{0})$. If we set $F(I) = y_0 \in Y^{(1)}$ and $G(I) = y_1 \in Y^{(1)}$, we have

$$\partial_0 y_0 = \partial_1 y_1.$$

What transitivity requires, is the existence of an element $y' \in Y^{(1)}$ such that

$$\partial_1 y' = \partial_1 y_0 \quad \partial_0 y' = \partial_0 y_1.$$

In general such an element does not exist.

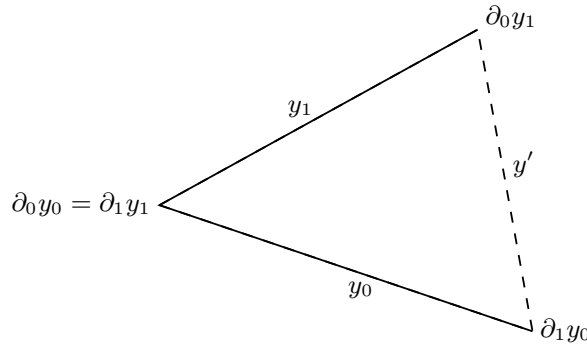

It was first observed by Kan (1957) that this difficulty can be avoided by assuming in Y the existence of an element $y \in Y^{(2)}$ such that

$$y_0 = \partial_2 y \quad \text{and} \quad y_1 = \partial_0 y$$

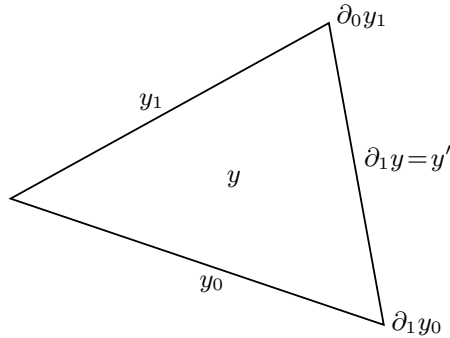

If such a simplex y exists, then $y' = \partial_1 y$ is the simplex we were looking for. In fact

$$\partial_1 y' = \partial_1 \partial_1 y = \partial_1 \partial_2 y = \partial_1 y_0$$

$$\partial_0 y' = \partial_0 \partial_1 y = \partial_0 \partial_0 y = \partial_0 y_1.$$

We are now ready for the general definition:

Definition An ss-set Y satisfies the Kan condition if, given simplices

$$y_0, \dots, y_{k-1}, y_{k+1}, \dots, y_{n+1} \in Y^{(n)}$$

such that $\partial_i y_j = \partial_{j-1} y_i$ for $i < j$ and $i, j \neq k$, there exists $y \in Y^{(n+1)}$ such that $\partial_i y = y_i$ for $i \neq k$.

Such an ss-set is said to be *Kan*. We shall prove later that for semisimplicial maps with values in a Kan ss-set, homotopy is an equivalence relation. $[f]_{\text{SS}}$, or $[f]$ for short, denotes the homotopy class of f . We abbreviate Kan ss-set to KSS-set.

Example $\text{Sing}(A)$ is a KSS-set. This follows from the fact that the star $S(v, \dot{\Delta})$ is a deformation retract of Δ for each vertex $v \in \Delta = \Delta^n$.

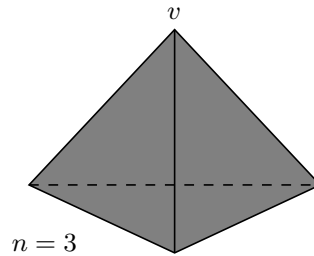

The union of three faces of the pyramid is a retract of the whole pyramid.

Exercise If Δ is a standard simplex, a *horn* Λ of Δ is, by definition, the star $S(v, \dot{\Delta})$, where v is a vertex of Δ . Check that an ss-set X is Kan if and only if each ss-map $\Lambda \rightarrow X$ extends to an ss-map $\Delta \rightarrow X$.

This exercise gives us an alternative definition of a KSS-set.

Note The extension property allowed DM Kan to develop the homotopy theory in the whole category of ss-sets. The original work of Kan in this direction was based on *semicubical complexes*, but it was soon clear that it could be translated to the semisimplicial environment. For technical reasons, the category of ss-sets replaced the analogous semicubical category, which, recently, regained a certain attention in several contexts, not the least in computing sciences.

In brief the greatest inconvenience in the semicubical category is the fact that the cone on a cube is not a combinatorial cube, while the cone on a simplex is still a simplex.

1.4 The topological realisation of an ss-set (Milnor 1958)

Let X be an ss-set and

$$\bar{X} = \coprod_n \Delta^n \times X^{(n)},$$

where $X^{(n)}$ has the discrete topology and \coprod denotes the disjoint union.

We define the *topological realisation of X*, written $|X|$, to be the quotient space of \overline{X} with respect to the equivalence relation generated by the following identifications

$$(t, \lambda^\# \theta) \sim (\lambda(t), \theta),$$

where $t \in \Delta^n$, $\lambda \in \Delta^*$ and $\theta \in X$.

Thus, the starting point is an infinite union of standard simplices each labelled by an element of X . We denote those simplices by Δ_θ^n instead of $\Delta^n \times \theta$ ($\theta \in X^{(n)}$).

The relation \sim is defined on labelled simplices by using the composition of the two elementary operations (a) and (b) described below. Let us consider Δ_τ^{n-1} and Δ_θ^n :

- (a) if $\tau = \partial_i \theta$ for some $i = 0, \dots, n$, then \sim identifies Δ_τ^{n-1} to $\partial_i(\Delta_\theta^n)$, ie, \sim glues to each simplex its faces
- (b) if $\tau = s_j \theta$ for some $j = 0, \dots, n-1$, then \sim squeezes the simplex Δ_θ^n on its j -th face, which in turn is identified with Δ_τ^{n-1} .

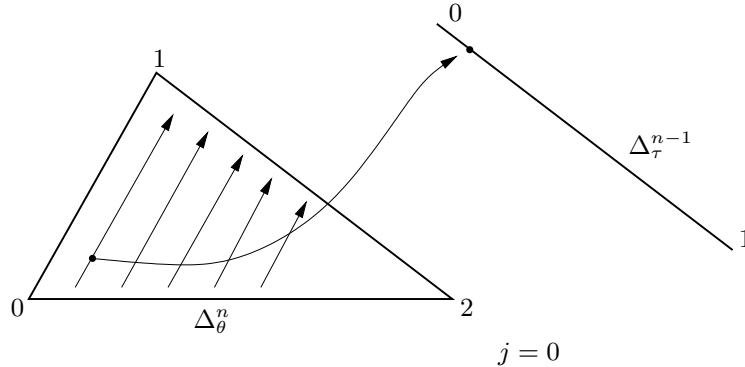

As a result $|X|$ acquires a CW-structure, with a k -cell for each *non degenerate* k -simplex of X with a canonical characteristic map $\Delta^k \rightarrow X$.

Examples

(a) If K is a simplicial complex and \mathbf{K} is its associated SS-set, then $|\mathbf{K}| = K$. In particular

$$|\Delta^n| = \Delta^n, \quad |\mathbf{I}| = I = [0, 1], \quad |\mathbf{0}| = 0; \quad |\mathbf{1}| = 1.$$

(b) $|\text{Sing}(\ast)| = \ast$.

(c) In general it can be proved that, for each CW-complex X , the realisation $|\text{Sing}(X)|$ is homotopy equivalent to X by the map

$$[t, \theta] \mapsto \theta(t)$$

where $\theta: \Delta^n \rightarrow X$ and $t \in \Delta^n$ and $[\]$ indicates equivalence class in $|\text{Sing}(X)|$.

(d) If X, Y are SS-sets then $|X \times Y|$ can be identified with $|X| \times |Y|$.

1.5 Approximation

Now we want to describe the realisation of an SS-map. If $f: X \rightarrow Y$ is such a map, we define its *realisation* $|f|: |X| \rightarrow |Y|$ by setting

$$[t, \theta] \mapsto [t, f(\theta)].$$

Clearly $|f|$ is well defined, since if $[t, \theta] = [s, \tau]$ and there is $\mu \in \Delta^*$, with $\mu^\#(\tau) = \theta$ and $\mu(t) = s$, then

$$\begin{aligned} |f|[t, \theta] &= [t, f(\theta)] = [t, f(\mu^\#(\tau))] = [t, \mu^\#f(\tau)] = \\ &= [\mu(t), f(\tau)] = |f|[\mu(t), \tau] = |f|[s, \tau]. \end{aligned}$$

We say that a (continuous) map $h: |X| \rightarrow |Y|$ is *realized* if $h = |f|$ for some $f: X \rightarrow Y$.

The following result is very useful.

Semisimplicial Approximation Theorem *Let $Z \subset X$ and Y be SS-sets, with Y a KSS-set, and let $g: |X| \rightarrow |Y|$ be such that its restriction to $|Z|$ is the realisation of an SS-map. Then there is a homotopy*

$$g \simeq g' \text{ rel } |Z|$$

such that g' is the realisation of an SS-map. □

A very short and elegant proof of the approximation theorem is due to [Sander-son 1975].

1.5.1 Corollary *Let Y be a KSS-set. Two SS-maps with values in Y are homotopic if and only if their realisations are homotopic.* □

1.5.2 Corollary *Homotopy between SS-maps is an equivalence relation, if the codomain is a KSS-set.* □

This is the result announced after Definition 1.3.

Exercise Convince yourself that an ordered simplicial complex seldom satisfies the Kan condition.

It is not a surprise that the semisimplicial approximation theorem provides a quick proof of Zeeman's relative simplicial approximation theorem (1964), given here in an intrinsic form:

Theorem (Zeeman 1959) *Let X, Y be polyhedra, Z a closed subpolyhedron in X and let $f: X \rightarrow Y$ be a map such that $f|Z$ is PL. Then, given $\varepsilon > 0$, there exists a PL map $g: X \rightarrow Y$ such that*

$$(1) \quad f|Z = g|Z \quad (2) \quad \text{dist}(f, g) < \varepsilon \quad (3) \quad f \simeq g \text{ rel } Z. \quad \square$$

The above theorem is important because, as observed by Zeeman himself, if $L \subset K$ and T are simplicial complexes, a standard result of Alexander (1915) tells us that each map $f: |K| \rightarrow |T|$, with $f|L$ simplicial, may be approximated by a simplicial map $g: K' \rightarrow T$, where $K' \triangleleft K$ such that $f|L$ in turn is *approximated* by $g|L'$. However, while this is sufficient in algebraic topology, in geometric topology we frequently need the strong version

$$f|L' = g|L'.$$

The interested reader might wish to consult [Glaser 1970, pp. 97–103], [Zeeman 1964].

1.6 Homotopy groups

If X is an ss-set, we call the *base point* of X a 0-simplex $*_X \in X^{(0)}$ or, equivalently, the sub ss-set $* \subset X$, generated by $*_X$. An ss-map $f: X \rightarrow Y$ is a *pointed map* if $f(*_X) = *_Y$.

As a consequence of the semisimplicial approximation theorem, the homotopy theory of ss-sets coincides with the usual homotopy theory of their realisations.

More precisely, let X, Y be pointed ss-sets, with $* \subset Y \subset X$. We define *homotopy groups* by setting

$$\begin{aligned} \pi_n(X, *) &:= \pi_n(|X|, *) \\ \pi_n(X, Y; *) &:= \pi_n(|X|, |Y|, *). \end{aligned}$$

We recall that from the approximation theorem that, if K is a simplicial complex and X a kss-set, then each map $f: K \rightarrow |X|$ is homotopic to a map $f': K \rightarrow |X|$ which is the realisation of an ss-map. Moreover, if f is already the realisation of a map on the subcomplex $L \subset K$, the homotopy can be taken to be constant on L . This property allows us to choose, according to our needs, suitable representatives for the elements of $\pi_n(X, *)$. As an example, we have:

$$\pi_n(X, *) := [I^n, \dot{I}^n; X, *]_{\text{SS}} = [\Delta^n, \dot{\Delta}^n; X, *]_{\text{SS}} = [S^n, 1; X, *]_{\text{SS}},$$

where I^n , or S^n , is given the structure of an ss-set by *any* ordered triangulation, which is, for convenience, very often omitted in the notation.

1.7 Fibrations

An ss-map $p: E \rightarrow B$ is a *Kan fibration* if, for each commutative square of ss-maps

$$\begin{array}{ccc} \Lambda & \longrightarrow & E \\ \downarrow & \nearrow & \downarrow p \\ \Delta & \longrightarrow & B \end{array}$$

there exists an ss-map $\Delta \rightarrow E$, which preserves commutativity. Here Δ and Λ represent a standard simplex and one of its horns respectively.

An equivalent definition of Kan fibration is the following: if $x \in B_{q+1}$ and $y_0, \dots, y_{k-1}, y_{k+1}, \dots, y_{q+1} \in E^{(q)}$ are such that $p(y_i) = \partial_i x$ and $\partial_i y_j = \partial_{i-1} y_i$ per $i < j$ and $j \neq k$, then there is $y \in E^{(q+1)}$, such that $\partial_i y = y_i$, for $i \neq k$ and $p(y) = x$.

If F is the preimage in E of the base point, then F is an ss-set, known as the *fibre* over $*$.

Lemma *Let $p: E \rightarrow B$ be a Kan fibration:*

- (a) *if F is the fibre over a point in B , then F is a KSS-set,*
- (b) *if p is surjective, E is Kan if and only if B is Kan.* □

The proof is left to the reader, who may appeal to [May 1967, pp. 25–27].

Theorem [Quillen 1968] *The geometric realisation of a Kan fibration is a Serre fibration.* □

Remark Quillen's proof is very short, but it relies on the theory of minimal fibrations, which we will not introduce in our brief outline of the ss-category as it is not explicitly used in the rest of the book. The same remark applies to Sanderson's proof of the simplicial approximation lemma. We refer the reader to [May 1967, pages 35–43]

As a consequence of this theorem and the definition of homotopy groups we deduce that, provided $p: E \rightarrow B$ is a Kan fibration with B a KSS-set, there is a *homotopy long exact sequence*:

$$\cdots \longrightarrow \pi_n(F) \longrightarrow \pi_n(E) \xrightarrow{p_*} \pi_n(B) \longrightarrow \pi_{n-1}(F) \longrightarrow \cdots$$

Suppose now that we have two ss-fibrations $p_i: E_i \rightarrow B_i$ ($i = 1, 2$) and let $f: E_1 \rightarrow E_2$ be an ss-map which covers an ss-map $f_0: B_1 \rightarrow B_2$. Assume all the ss-sets are Kan and fix a base point in each path component so that p_i, f, f_0 are pointed maps.

Proposition *Let p_i, f, f_0 be as above. Any two of the following properties imply the remaining one:*

- (a) f is a homotopy equivalence,
- (b) f_0 is a homotopy equivalence,
- (c) the restriction of f to the fibre of E_1 over the base point of each path component B_1 is a homotopy equivalence with the corresponding fibre of E_2 .

Proof This result is an immediate consequence of the long exact sequence in homotopy, Whitehead's Theorem and the Five Lemma. \square

1.8 The homotopy category of SS-sets

Although it will be used very little, the content of this section is quite important, as it clarifies the role of the category of SS-sets in homotopy theory.

We denote by **SS** (resp **KSS**) the category of SS-sets (resp KSS-sets) and SS-maps, and by **CW** the category of CW-complexes and continuous maps.

The geometric realisation gives rise to a functor $|\cdot|: \mathbf{SS} \rightarrow \mathbf{CW}$. We also consider the singular functor $S: \mathbf{CW} \rightarrow \mathbf{SS}$.

Theorem (Milnor) *The functors $|\cdot|$ and S induce inverse isomorphisms between the homotopy category of KSS-sets and the homotopy category of CW-complexes:*

$$h \mathbf{KSS} \begin{array}{c} \uparrow \downarrow \\ \xleftarrow{S} \xrightarrow{|\cdot|} \\ \downarrow \uparrow \end{array} h \mathbf{CW} \quad \square$$

For a full proof, see, for instance, [May 1967, pp. 61–62].

Hence, there is a natural bijection between the homotopy classes of SS-maps $[\text{Sing}(X), Y]$ and the homotopy classes of maps $[X, |Y|]$, provided that X has the homotopy type of a CW-complex and Y is a KSS-set. Sometimes, we write just $[X, Y]$ for either set.

In conclusion, as indicated earlier, we observe that the semisimplicial structure provides us with a simple, safe and effective way to introduce a good topology, even a CW structure, on the PL function spaces that we will consider. This topology will allow the application of tools from classical homotopy theory.

Terminology For convenience, whenever there is no possibility of misunderstandings we will confuse X and its realisation $|X|$. Moreover, unless otherwise stated, all the maps from $|X|$ to $|Y|$ are always intended to be realised and, therefore, abusing language, we will refer to such maps as semisimplicial maps.

2 Topological and PL microbundles

Each smooth manifold has a well determined tangent vector bundle. The same does not hold for topological manifolds. However there is an appropriate generalisation of the notion of a tangent bundle, introduced by Milnor (1958) using microbundles.

2.1 Topological microbundles

A *microbundle* ξ , with *base* a topological space B , is a diagram of maps

$$B \xrightarrow{i} E \xrightarrow{p} B$$

with $p \circ i = 1_B$, where i is the *zero-section* and p is the *projection* of ξ .

A microbundle is required to satisfy a *local triviality* condition which we will state after some examples and notation.

Notation We write $E = E(\xi)$, $B = B(\xi)$, $p = p_\xi$, $i = i_\xi$ etc. We also write ξ/B and E/B to refer to ξ . Further B is often identified with $i(B)$.

Examples

(a) The *product microbundle*, with *fibre* \mathbb{R}^m and *base* B , is given by

$$\varepsilon_B^m: B \xrightarrow{i} B \times \mathbb{R}^m \xrightarrow{\pi_1} B$$

with $i(b) = (b, 0)$ and $\pi_1(b, v) = b$.

(b) More generally, any vector bundle with fibre \mathbb{R}^m is, in a natural way, a microbundle.

(c) If M is a topological manifold without boundary, the *tangent microbundle* of M , written TM , is the diagram

$$M \xrightarrow{\Delta} M \times M \xrightarrow{\pi_1} M$$

where Δ is the diagonal map and π_1 is the projection on the first factor.

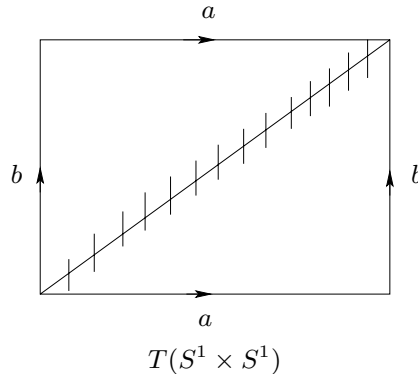

Microbundles maps

2.2 An *isomorphism*, between microbundles on the same base B ,

$$\xi_\alpha: B \xrightarrow{i_\alpha} E_\alpha \xrightarrow{p_\alpha} B \quad (\alpha = 1, 2),$$

is a commutative diagram

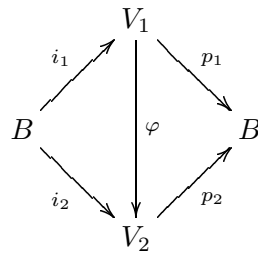

where V_α is an open neighbourhood of $i_\alpha(B)$ in E_α and φ is a homeomorphism.

2.2.1 In particular, if E/B is a microbundle and U is an open neighbourhood of $i(B)$ in E , then U/B is a microbundle isomorphic to E/B .

Exercise

Prove that, if M is a smooth manifold, its tangent vector bundle and its tangent microbundle are isomorphic as microbundles.

Hint Put a metric on M . If the points $x, y \in M$ are close enough, consider the unique short geodesic from x to y and associate to (x, y) the pair having x as first component and the velocity vector at x as second component.

Observation Any $(\mathbb{R}^m, 0)$ -bundle on B is a microbundle, and isomorphic bundles are isomorphic as microbundles.

2.3 More generally, a microbundle *map*

$$\xi_\alpha: B_\alpha \xrightarrow{i_\alpha} E_\alpha \xrightarrow{p_\alpha} B_\alpha \quad \alpha = 1, 2$$

is a commutative diagram

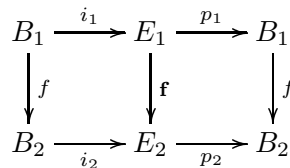

where V_1 is an open neighbourhood of $i_1(B_1)$ in E_1 and \mathbf{f} , f are continuous maps. We write $\mathbf{f}: \xi_1 \rightarrow \xi_2$ meaning that \mathbf{f} covers $f: B_1 \rightarrow B_2$. Occasionally, in order to be more precise, we will write $(\mathbf{f}, f): \xi_1 \rightarrow \xi_2$. For isomorphisms we shall use the imprecise notation since, by definition, each isomorphism $\rho: \xi_1/B \approx \xi_2/B$ covers 1_B .

A map $f: M \rightarrow N$ of topological manifolds induces a map between tangent microbundles

$$df: TM \rightarrow TN,$$

known as the *differential* of f and defined as follows

$$\begin{array}{ccccc} M & \xrightarrow{\Delta} & M \times M & \longrightarrow & M \\ \downarrow f & & \downarrow f \times f & & \downarrow f \\ N & \xrightarrow{\Delta} & N \times N & \longrightarrow & N \end{array}$$

Note As we have already observed, each microbundle is isomorphic to any open neighbourhood of its zero-section; in other words, what really matters in a microbundle is its behaviour near its zero-section.

In particular, the tangent microbundle TM can, in principle, be constructed by choosing, in a continuous way, a chart U_x around x as a fibre over $x \in M$. Yet, as we do not have canonical charts for M , such a choice is not a topological invariant of M : this is where the notion of microbundle comes in to solve the problem, telling us that we are not forced to select a specific chart U_x , since a *germ* of a chart (defined below) is sufficient. The name *microbundle* is due to Arnold Shapiro.

2.4 Induced microbundle

If ξ is a microbundle on B and $A \subset B$, the *restriction* $\xi|_A$ is the microbundle obtained by restricting the total space, ie,

$$\xi|_A: A \rightarrow p_\xi^{-1}(A) \xrightarrow{p_\xi} A$$

More generally, if ξ/B is a microbundle and $f: A \rightarrow B$ is a map of topological spaces, the *induced* microbundle $f^*(\xi)$ is defined via the usual categorical construction of pull-back of the map p_ξ over the map f .

Example If $f: M \rightarrow N$ is a map of topological manifolds, then $f^*(TN)$ is the microbundle

$$M \xrightarrow{i} M \times N \xrightarrow{\pi_1} M$$

with $i(x) = (x, f(x))$.

2.5 Germs

Two microbundle maps $(\mathbf{f}, f): \xi_1 \rightarrow \xi_2$ and $(\mathbf{g}, g): \xi_1 \rightarrow \xi_2$ are *germ equivalent* if \mathbf{f} and \mathbf{g} agree on some neighbourhood of B_1 in E_1 . The germ equivalence class of (\mathbf{f}, f) is called the *germ of (\mathbf{f}, f)* or less precisely the *germ of \mathbf{f}* . The notion of the *germ* of a map (or isomorphism) is far more useful and flexible than that of map or isomorphism of microbundles because unlike maps and isomorphisms, *germs can be composed*. Therefore we have the *category of microbundles and germs of maps of microbundles*.

From now on, unless there is any possibility of confusion, we will use interchangeably, both in the notation and in the exposition, the germs and their representatives.

2.6 Local triviality

A microbundle ξ/B is *locally trivial*, of dimension or rank m , or, more simply, an *m -microbundle*, if it is locally isomorphic to the product microbundle ε_B^m . This means that each point of B has a neighbourhood U in B such that $\varepsilon_U^m \approx \xi|U$.

An m -microbundle ξ/B is *trivial* if it is isomorphic to ε_B^m .

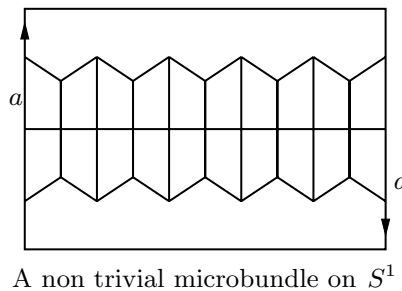
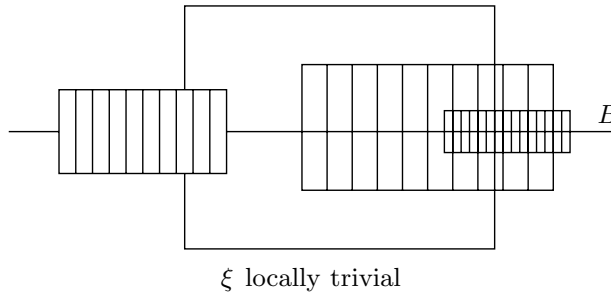

Examples

(a) The tangent microbundle TM^m is locally trivial of rank m .

In fact, let $x \in M$ and (U, φ) be a chart of M on a neighbourhood of x such that $\varphi(U) \subset \mathbb{R}^m$. Define $h_x: U \times \mathbb{R}^m \rightarrow U \times U$ near $U \times 0$ by

$$h_x(u, v) = (u, \varphi^{-1}(\varphi(u) + v)).$$

(b) If ξ/B is an m -microbundle and $f: A \rightarrow B$ is continuous, then the induced microbundle $f^*(\xi)$ is locally trivial. This follows from two simple facts:

(1) If ξ is trivial, then $f^*(\xi)$ is trivial.

(2) If $U \subset B$ and $V = f^{-1}(U) \subset A$, then

$$f^*(\xi)|V = (f|V)^*(\xi|U).$$

Terminology From now on the term *microbundle* will always mean *locally trivial microbundle*.

2.7 Bundle maps

With the notation used in 2.3, the germ of a map (\mathbf{f}, f) of m -microbundles is said to be *locally trivial* if, for each point x , of B_1 , \mathbf{f} restricts to a germ of an isomorphism of $\xi_1|x$ and $\xi_2|f(x)$. Once the local trivialisations have been chosen this germ is nothing but a germ of isomorphism of $(\mathbb{R}^m, 0)$ (as a microbundle over 0) to itself.

A locally trivial map is called a *bundle map*. Thus a map is a bundle map if, restricted to a convenient neighbourhood of the zero-section, it respects the fibres and it is an open topological embedding on each fibre. Note that an isomorphism between m -microbundles is automatically a bundle map.

Terminology We often refer to an isomorphism between m -microbundles as a *micro-isomorphism*.

Examples

(a) If $f: M \rightarrow N$ is a homeomorphism of topological manifolds, its differential $df: TM \rightarrow TN$ is a bundle map. It will be enough to observe that, since it is a local property, it is sufficient to consider the case of a homeomorphism $f: \mathbb{R}^m \rightarrow \mathbb{R}^m$. This is a simple exercise.

(b) Going back to the induced bundle, there is a natural bundle map $\mathbf{f}: f^*(\xi) \rightarrow \xi$. The universal property of the fibre product implies that \mathbf{f} is, essentially, the

only example of a bundle map. In fact, if $\mathbf{f}' : \eta \rightarrow \xi$ is a bundle map which covers f , then there exists a unique isomorphism $\mathbf{h} : \eta \rightarrow f^*(\xi)$ such that $\mathbf{f} \circ \mathbf{h} = \mathbf{f}'$:

$$\begin{array}{ccc} \eta & \xrightarrow{\mathbf{h}} & f^*(\xi) \\ & \searrow \mathbf{f}' & \downarrow \mathbf{f} \\ & & \xi \end{array}$$

(c) It follows from (b) that if $f : A \rightarrow B$ is a continuous map then each isomorphism $\varphi : \xi_1/B \rightarrow \xi_2/B$ induces an isomorphism $f^*(\varphi) : f^*(\xi_1) \rightarrow f^*(\xi_2)$.

2.8 The Kister–Mazur theorem.

Let $\xi : B \xrightarrow{i} E \xrightarrow{p} B$ be an m –microbundle, then we say that ξ *admits* or *contains* a bundle, if there exists an open neighbourhood E_1 of $i(B)$ in E , such that $p : E_1 \rightarrow B$ is a topological bundle with fibre $(\mathbb{R}^m, 0)$ and zero–section $i(B)$. Such a bundle is called *admissible*.

The reader is reminded that an isomorphism of $(\mathbb{R}^m, 0)$ –bundles is a topological isomorphism of \mathbb{R}^m –bundles, which is the identity on the 0–section.

Theorem (Kister, Mazur 1964) *If an m –microbundle ξ has base B which is an ENR then ξ admits a bundle, unique up to isomorphism.* □

The reader is reminded that ENR is the acronym for *Euclidean Neighbourhood Retract* and therefore the result is valid, in particular, in those cases when B is a locally finite Euclidean polyhedron or a topological manifold. The proof of this difficult theorem, for which we refer the reader to [Kister 1964], is based upon a lemma which is interesting in itself. Let \mathcal{G}_0 be the space of the topological embeddings of $(\mathbb{R}^m, 0)$ in itself with the compact open topology and let \mathcal{H}_0 be the subspace of proper homeomorphisms of $(\mathbb{R}^m, 0)$. The lemma states that \mathcal{H}_0 is a deformation retract of \mathcal{G}_0 , ie, there exists a continuous map $F : \mathcal{G}_0 \times I \rightarrow \mathcal{G}_0$ so that $F(g, 0) = g$, $F(g, 1) \in \mathcal{H}_0$ for each $g \in \mathcal{G}_0$ and $F(h, t) \in \mathcal{H}_0$ for each $t \in I$ and $h \in \mathcal{H}_0$.

In the light of this result it makes sense to expect the fact that two admissible bundles are not only isomorphic but even *isotopic*. This fact is proved by Kister.

Note In principle Kister’s theorem would allow us to work with genuine \mathbb{R}^m –bundles which are more familiar objects than microbundles. In fact, according to definition 2.5, a microbundle ξ is micro-isomorphic to each of its admissible bundles.

It is not surprising if Kister's discovery took, at first, some of the sparkle from the idea of microbundle. Nevertheless, it is in the end convenient to maintain the more sophisticated notion of microbundle, since, for instance, the tangent microbundle of a topological manifold is a canonical object while the admissible tangent bundle is defined only up to isomorphism.

2.9 Microbundle homotopy theorem

The microbundle homotopy theorem states that *each microbundle $\xi/X \times I$, where X is a paracompact Hausdorff space, admits an isomorphism $\varphi: \xi \approx \eta \times I$, where η is a copy of $\xi|X \times 0$* . There is also a *relative version* of this result, where, given C a closed subset of X and an isomorphism $\varphi': (\xi|U) \times I$, where U is an open neighbourhood of C in X , it is possible to choose φ to coincide with φ' on an appropriate neighbourhood of C .

Kister's result reduces this theorem to the analogous and more familiar result concerning bundles with fibre \mathbb{R}^m [cf Steenrod 1951, section 11].

The following important property follows immediately from the homotopy theorem.

Proposition *If f, g are continuous homotopic maps, of a paracompact Hausdorff space X to Y and if ξ/Y is an m -microbundle, then $f^*(\xi) \approx g^*(\xi)$.* \square

2.10 PL microbundles

The category of PL microbundles and maps is defined in analogy to the corresponding topological case using polyhedra and PL maps, with obvious changes. For example, each PL manifold without boundary M admits a well defined PL *tangent microbundle* given by

$$M \xrightarrow{\Delta} M \times M \xrightarrow{\pi_1} M .$$

A PL map $f: M^m \rightarrow N^m$ induces a *differential* $df: TM \rightarrow TN$, which is a PL map of PL m -microbundles. The PL microbundle $f^*(\xi)$, *induced* by a PL map of polyhedra, is defined in the usual way through the categorical construction of the pullback and the natural map $f^*(\xi) \rightarrow \xi$ is locally trivial (ie is a PL *bundle map*) if ξ is locally trivial.

As in the topological case PL microbundle will always mean PL *locally trivial microbundle*.

The PL version of Kister–Mazur theorem is proved in [Kuiper–Lashof 1966].

Finally, the *homotopy theorem* for the PL case asserts that, if X is a polyhedron, then $\xi/X \times I \approx \eta \times I$, with $\eta = \xi|X \times 0$. Nevertheless the proposition that follows from it is less obvious than its topological counterpart.

Proposition *Let $f, g: X \rightarrow Y$ be PL maps of polyhedra and assume that f, g are continuously homotopic. Let ξ/Y be a PL m -microbundle. Then*

$$f^*(\xi) \approx_{\text{PL}} g^*(\xi).$$

Proof Let $F: X \times I \rightarrow Y$ be homotopy of f and g . By Zeeman's relative simplicial approximation theorem, there exists a homotopy $F': X \times I \rightarrow Y$ of f and g , with F' a PL map. The remaining part of the proof is then clear. \square

3 The classifying spaces BPL_m and $BTop_m$

Now we want to prove the existence of classifying spaces for PL m -microbundles and topological m -microbundles. The question fits in the general context of the construction of the classifying space BG of a simplicial group (monoid) G . On this problem, at the time, a large amount of literature was produced and of this we will just cite, also making a reference for the reader, [Eilenberg and MacLane 1953, 1954], [Maclane 1954], [Heller 1955], [Milnor 1961], [Barratt, Gugenheim and Moore 1959], [May 1967], [Rourke and Sanderson 1971]. The first to construct a semisimplicial model for BPL_m and $BTop_m$ was Milnor prior to 1961.

The semisimplicial groups Top_m and PL_m

3.1 We remind the reader that a semisimplicial group G is a contravariant functor from the category Δ^* to the category of groups. From now on e_m will denote the identity in $G^{(m)} = G(\Delta^m)$.

We define the ss-set Top_m to have typical k -simplex φ a micro-isomorphism

$$\varphi: \Delta^k \times \mathbb{R}^m \rightarrow \Delta^k \times \mathbb{R}^m.$$

For each $\lambda: \Delta^l \rightarrow \Delta^k$ in Δ^* , we define

$$\lambda^\#: Top_m^{(k)} \rightarrow Top_m^{(l)}$$

by setting $\lambda^\#(\varphi)$ to be equal to the micro-isomorphism induced by φ according to 2.7 (c):

$$\begin{array}{ccc} \Delta^l \times \mathbb{R}^m & \xrightarrow{\lambda^\#(\varphi)} & \Delta^l \times \mathbb{R}^m \\ \lambda \times 1 \downarrow & & \downarrow \lambda \times 1 \\ \Delta^k \times \mathbb{R}^m & \xrightarrow{\varphi} & \Delta^k \times \mathbb{R}^m \end{array}$$

The operation of composition of micro-isomorphisms makes $Top_m^{(k)}$ into a group and $\lambda^\#$ a homomorphism of groups. Therefore Top_m is a semisimplicial group.

3.2 In topological m -microbundle theory Top_m plays the role played by the linear group $GL(m, \mathbb{R})$ in vector bundle theory. Furthermore it can be thought of as the singular complex of the space of germs of the homeomorphisms of $(\mathbb{R}^m, 0)$ to itself.

3.3 Since $|\Delta^k| \approx |\Lambda^k \times I|$, it follows that Top_m satisfies the Kan condition. On the other hand we have the following general result, whose proof is left to the reader.

Proposition *Each semisimplicial group satisfies the Kan condition.*

Proof See [May 1967, p. 67]. □

3.4 The semisimplicial group PL_m is defined in a totally analogous manner and, from now on, the exposition will concentrate on the PL case.

3.5 Steenrod's criterion

The classification of bundles of base X in the classical approach of [Steenrod 1951] is done through the following steps:

- (a) there is a one to one canonical correspondence

$$[\mathbb{R}^m\text{-vector bundles}] \equiv [GL(m, \mathbb{R})\text{-principal bundles}]$$

More generally

$$[\text{bundles with fibre } F \text{ and structure group } G] \equiv [G\text{-principal bundles}]$$

where $[\]$ indicates the isomorphism classes;

- (b) *recognition criterion*: there exists a classifying principal bundle

$$\gamma_G: G \rightarrow EG \rightarrow BG$$

which is characterised by the fact that E is path connected and $\pi_q(E) = 0$ if $q \geq 1$. The homotopy type of BG is well defined and it is called the *classifying space* of the group G , or also classifying space for principal G -bundles with base a CW-complex.

The correspondence (a) assigns to a bundle ξ , with group G and fibre F , the *associated principal bundle* $\text{Princ}(\xi)$, which is obtained by assuming that the transitions maps of ξ do not operate on F any longer but operate by translation on G itself. The inverse correspondence assigns to a principal G -bundle, E/X , the bundle obtained by *changing the fibre*, ie the bundle

$$F \rightarrow E \times_G F \rightarrow X.$$

It follows that by changing the fibre of γ_G , we obtain the classifying bundle for the bundles with group G and fibre F , so that BG is the classifying space also for those bundles. Obviously we are assuming that there is a left action of G on the space F , which is not necessarily effective, so that

$$E \times_G F := E \times F / (xg, y) \sim (x, gy), \quad y \in F.$$

We will follow the outline explained above adapting it to the semisimplicial case.

3.6 Semisimplicial principal bundles

Let G be a semisimplicial group. Then a *free action* of G on the ss-set E is an ss-map $E \times G \rightarrow E$, such that, for each $\theta \in E^{(k)}$ and $g', g'' \in G^{(k)}$, we have: (a) $(\theta g')g'' = \theta(g'g'')$; (b) $\theta e_k = \theta$; (c) $\theta g' = \theta g'' \Leftrightarrow g' = g''$.

The space X of the orbits of E with respect to the action of G is an ss-set and the natural projection $p: E \rightarrow X$ is called a G -*principal bundle*. The reader can observe that neither E , nor X are assumed to be Kan ss-sets.

Proposition $p: E \rightarrow X$ is a Kan fibration.

Proof Let Λ^k be the k -horn of Δ^k , ie $\Lambda^k = S(v_k, \dot{\Delta}^k)$. We need to prove the existence of a map α which preserves the commutativity of the diagram below.

$$\begin{array}{ccc}
 \Lambda^k & \xrightarrow{\gamma} & E \\
 \downarrow & \alpha \nearrow & \downarrow p \\
 \Delta & \xrightarrow{\alpha} & X
 \end{array}$$

To start with consider *any* lifting α' of α , which is not necessarily compatible with γ . Let $\varepsilon: \Lambda^k \rightarrow G$ be defined by the formula

$$\alpha'(x)\varepsilon(x) = \gamma(x).$$

Since G satisfies the Kan condition, ε extends to $\varepsilon: \Delta^k \rightarrow G$. If we set

$$\alpha(x) := \alpha'(x)\varepsilon(x);$$

then α is the required lifting. □

The theory of semisimplicial principal G -bundles is analogous to the theory of principal bundles, developed by [Steenrod, 1951] for the topological case. In particular we leave to the reader the task of defining the notion of *isomorphism of G -bundles*, of *trivial G -bundle*, of *G -bundle map*, of *induced G -bundle* and we go straight to the main point.

For each ss-set X let $\text{Princ}(X)$ be the set of isomorphism classes of principal G -bundles on X and, for each ss-map $f: X \rightarrow Y$, let $f^*: \text{Princ}(Y) \rightarrow \text{Princ}(X)$ be the induced map: Princ is a contravariant functor with domain the category **SS**. Our aim is to represent this functor.

3.7 The construction of the universal bundle

Steenrod's recognition criterion 3.5 (b) is carried unchanged to the semisimplicial case with a similar proof. Then it is a matter of constructing a principal G -bundle $\gamma: G \rightarrow EG \rightarrow BG$, such that

- (i) EG and BG are Kan ss-sets
- (ii) EG is contractible.

▼

We will follow the procedure used by [Heller 1955] and [Rourke–Sanderson 1971]. If X is an ss-set, let

$$X_S := \bigcup_0^\infty X^{(k)}.$$

In other words X_S is the graded set consisting of all the simplexes of X , without the face and degeneracy operators. We will denote with $EG(X)$ the totality of the maps of sets f with domain X_S and range G_S , which have degree zero, ie $f(X^{(k)}) \subset G^{(k)}$.

Since $G^{(k)}$ is a group, then also $EG(X)$ is a group.

Let $G(X)$ be the subgroup consisting of those maps of sets which commute with the semisimplicial operators, ie, those maps of sets which are restrictions of ss-maps. For each $k \geq 0$ we define

$$EG^{(k)} := EG(\Delta^k),$$

and we observe that $G(\Delta^k)$ is a group isomorphic to $G^{(k)}$, the isomorphism being the map which associates to each element of $G^{(k)}$ its characteristic map, $\Delta^k \rightarrow G$, thought of as a graded function $\Delta_S^k \rightarrow G_S$ (cf II 1.1).

Now it remains to define the semisimplicial operators in

$$EG = \bigcup_0^\infty EG^{(k)}.$$

Let $\lambda: \Delta^l \rightarrow \Delta^k$ be a morphism of Δ^* and let $\lambda_S: \Delta_S^l \rightarrow \Delta_S^k$ be the corresponding map of sets. For each $\theta \in EG^{(k)}$ we define

$$\lambda^\# \theta := \theta \circ \lambda_S: \Delta_S^l \rightarrow G_S$$

where $\lambda^\#: EG^{(k)} \rightarrow EG^{(l)}$ is a homomorphism of groups.

▲

This concludes the definition of an ss-set EG , which even turns out to be a group which has a copy of G as semisimplicial subgroup.

▼

Furthermore, it follows from the definition above, that there is a natural identification:

$$EG(X) \equiv \{\text{ss-maps } X \rightarrow EG\} \tag{3.7.1}$$

The reader is reminded that $EG(X)$ is the set of the degree-zero maps of sets from X_S to G_S .

▲

Proposition EG is Kan and contractible.

▼

Proof We claim that each SS-map $\partial\Delta^k \rightarrow EG$ extends to Δ^k . This follows from (3.7.1) and from the fact that each map of sets of degree zero $\partial\Delta_S^k \rightarrow G_S$ obviously admits an extension to Δ_S^k . The result follows straight away from this claim. \square

▲

At this point we define

$$BG := EG/G,$$

the SS-set of the right cosets of G in EG , and set $p_\gamma: EG \rightarrow BG$ to be equal to the natural projection.

In this way we have constructed a principal G -bundle γ/BG with $E(\gamma) = EG$. It follows from Lemma 1.7 that BG is a Kan SS-set.

The following *classification theorem* for semisimplicial principal G -bundles has been established.

Theorem BG is a classifying space for the group G , ie, the natural transformation

$$T: [X; BG] \rightarrow \text{Princ}(X),$$

defined by $T[f] := [f^*(\gamma)]$ is a natural equivalence of functors. \square

Corollary If $H \subset G$ is a semisimplicial subgroup, then there exists, up to homotopy, a fibration

$$G/H \rightarrow BH \rightarrow BG.$$

Proof Factorise the universal bundle of G through H and use the fact that, by the Steenrod's recognition principle,

$$EG/H \simeq BH. \quad \square$$

Observation If $H \subset G$ is a subgroup, then the quotient

$$H \rightarrow G \rightarrow G/H$$

is a principal H -fibration and, by lemma 1.7, G/H is Kan.

Classification of m -microbundles

3.8 So far we have established part (b) of 3.5 for principal G -bundles. Now we assume that $G = PL_m$ and we will examine part (a). Let K be a locally finite simplicial complex. Order the vertices of K . We consider the associated ss-set \mathbf{K} , which consists of all the monotone simplicial maps $f: \Delta^q \rightarrow K$ ($q = 0, 1, 2, \dots$), with $\lambda^\#: \mathbf{K}^q \rightarrow \mathbf{K}^r$ given by $\lambda^\#(f) = f \circ \lambda$ with $\lambda \in \Delta^*$.

We will denote by $\text{Micro}(K)$ the set of the isomorphism classes of m -microbundles on K and by $\text{Princ}(\mathbf{K})$ the set of the isomorphism classes of PL principal m -bundles with base \mathbf{K} .

Theorem *There is a natural one to one correspondence*

$$\text{Micro}(K) \approx \text{Princ}(\mathbf{K}).$$

▼

Proof If ξ/K is an m -microbundle, the *associated principal bundle* $\text{Princ}(\xi)$ is defined as follows:

- 1) a q -simplex of the total space E of $\text{Princ}(\xi)$ is a microisomorphism

$$\mathbf{h}: \Delta^q \times \mathbb{R}^m \rightarrow f^*(\xi)$$

with $f \in \mathbf{K}^q$. The semisimplicial operators $\lambda^\#: E^{(q)} \rightarrow E^{(r)}$ are defined by the formula

$$\lambda^\#(f, \mathbf{h}) := (\lambda^\#(f), \lambda^*(\mathbf{h}))$$

- 2) the projection $p: E^{(q)} \rightarrow \mathbf{K}$ is given by $p(\mathbf{h}) = f$
- 3) the action $E^{(q)} \times PL_m^{(q)} \rightarrow E^{(q)}$ is the composition of micro-isomorphisms.

Since $PL_m^{(q)}$ acts freely on $E^{(q)}$ with orbit space $\mathbf{K}^{(q)}$, then the projection $p: E \rightarrow \mathbf{K}$ is, by definition, a PL principal m -bundle.

Conversely, given a PL principal m -bundle η/\mathbf{K} , we can construct an m -microbundle on K as follows: Let $\alpha: K \rightarrow E(\eta)$ be any map which associates with each ordered q -simplex θ in K a q -simplex $\alpha(\theta)$ in $E(\eta)$, such that $p_\eta \alpha(\theta) = \theta$. Then there exists $\varphi(i, \theta) \in PL_m^{(q-1)}$ such that

$$\partial_i \alpha(\theta) = \alpha(\partial_i \theta) \varphi(i, \theta).$$

Furthermore $\varphi(i, \theta)$ is uniquely determined. Let us now consider the disjoint union of trivial bundles ε_θ^m with θ in K . We glue together such bundles by identifying each $\varepsilon_{\partial_i \theta}^m$ with $\varepsilon_\theta^m | \partial_i \theta$ through the micro-isomorphism defined by $\varphi(i, \theta)$ and by the ordering of the vertices of θ . The reader can verify that such identifications are compatible when restricted to any face of θ . Therefore an m -microbundle is defined $\eta[\mathbb{R}^m]/K$. It is not difficult to convince oneself that the two correspondences constructed

$$\begin{array}{ll} \xi \longrightarrow \text{Princ}(\xi) & \text{(associated principal bundle)} \\ \eta \longrightarrow \eta[\mathbb{R}^m] & \text{(change of fibre)} \end{array}$$

are inverse of each others. This proves the theorem. \square

▲

3.9 A certain amount of technical detail which is necessary for a rigorous treatment of the classification of microbundles has been omitted, particularly the part concerning the naturality of various constructions. However the main points have been explained and we move on to state the final result. To do this we need to define a microbundle with base an ss-set X . For what follows it suffices for the reader to think of a microbundle with base X as a microbundle with base $|X|$. Readers who are concerned about the technical details here may read the following inset material.

▼

It the topological case it is quite satisfactory to regard a microbundle ξ/X as a microbundle $\xi/|X|$, however in the PL case it is not clear how to give $|X|$ the necessary PL structure so that a PL microbundle over $|X|$ makes sense. We avoid this problem by defining a PL microbundle ξ/X to comprise a collection of PL microbundles with bases the simplexes of X glued together by PL microbundle maps corresponding to the face maps of X .

More precisely, for each $\sigma \in X^{(k)}$ we have a PL microbundle ξ_σ/Δ^k and for each pair $\sigma \in X^{(k)}, \tau \in X^{(l)}$ and monotone map $\lambda: \Delta^l \rightarrow \Delta^k$ such that $\lambda^\#(\sigma) = \tau$ an isomorphism

$$\lambda_{\sigma\tau}^\#: \xi_\tau \approx \lambda^* \xi_\sigma$$

which is functorial ie, $(\lambda \circ \mu)_{\sigma\rho}^\# = \mu^*(\lambda_{\sigma\tau}^\#) \circ \mu_{\tau\rho}^\#$

where $\mu: \Delta^j \rightarrow \Delta^l$ and $\mu^\#(\tau) = \rho$. Another way of putting this is that we have a lifting of X (as a functor) to the category of PL microbundles and bundle maps. More precisely associate a category \tilde{X} with X by $\text{Ob}(\tilde{X}) = \sum_n X^{(n)}$ and $\text{Map}(\tilde{X})(\tau, \sigma) = \{(\lambda, \tau, \sigma) : \lambda^\# \sigma = \tau\}$ for $\sigma, \tau \in \text{Ob}(\tilde{X})$. Composition of maps in \tilde{X} is given by $(\lambda, \tau, \sigma) \circ (\mu, \rho, \tau) = (\lambda\mu, \rho, \sigma)$. A PL microbundle ξ/X is then a functor ξ from \tilde{X} to the category of PL microbundles and bundle maps such that for each $\sigma \in X^{(n)}$, $\xi_\sigma = \xi(\sigma)$ is a microbundle with base Δ^n .

The definition implies that the microbundles ξ_σ can be glued to form a (topological) microbundle with base $|X|$.

▲

Let BPL_m be the classifying space of the group $G = \text{PL}_m$ constructed in 3.7. Theorem 3.7 now implies that we have a PL microbundle $\gamma_{\text{PL}}^m/\text{BPL}_m$ which we call the *classifying bundle* and we have the following classification theorem.

Theorem BPL_m is a classifying space for PL m -microbundles which have a polyhedron as base. Precisely, there exists a PL m -microbundle $\gamma_{\text{PL}}^m/\text{BPL}_m$, such that the set of the isomorphism classes of PL m -microbundles on a fixed polyhedron X is in a natural one to one correspondence with $[X, \text{BPL}_m]$ through the induced bundle. \square

3.10 Milnor (1961) also proved that the *homotopy type of BPL_m contains a locally finite simplicial complex.*

His argument proceeds through the following steps:

- (a) for each finite simplicial complex K the set $\text{Micro}(K)$ is countable
- (b) by taking K to be a triangulation of the sphere S^q deduce that each homotopy group $\pi_q(BPL_m)$ is countable
- (c) the result then follows from [Whitehead 1949, p. 239].

The theorem of Whitehead, to which we referred, asserts that each countable CW-complex is homotopically equivalent to a locally finite simplicial complex. We still have to prove that each CW-complex whose homotopy groups are countable is homotopically equivalent to a countable CW-complex, for more detail here, see subsection 3.13 below.

Note By virtue of 3.10 and of the Zeeman simplicial approximation theorem it follows that

$$[X, BPL_m]_{\text{PL}} \equiv [X, BPL_m]_{\text{Top}}.$$

3.11 Let $BTop_m$ be the classifying space of $G = \text{Top}_m$. Then we have, as above:

Theorem $BTop_m$ classifies topological m -microbundles with base a polyhedron. □

Addendum $BTop_m$ even classifies the m -microbundles with base X , where X is an ENR. In particular X could be a topological manifold.

Proof of the addendum Let $\gamma_{\text{Top}}^m/BTop_m$ be a universal m -dimensional microbundle, which certainly exists, and let $N(X)$ be an open neighbourhood of X in a Euclidean space having X as a retract. Let $r: N(X) \rightarrow X$ be the retraction. Assume that ξ/X is a topological m -bundle and take $r^*(\xi)/N(X)$. By the classification theorem there exists a classifying function

$$(\mathbf{F}, F): r^*(\xi) \rightarrow \gamma_{\text{Top}}^m.$$

Since $r^*(\xi)|_X = \xi$, then $(\mathbf{F}, F)|_\xi$ classifies ξ . □

From now on we will write G_m to indicate, without distinction, either Top_m or PL_m .

3.12 There are also *relative versions* of the classifying theorems which assert that, if $C \subset X$ is closed and U is an open neighbourhood of C in X and if $\mathbf{f}_U: \xi|U \rightarrow \gamma_G^m$ is a classifying map, then there exists a classifying map $\mathbf{f}: \xi \rightarrow \gamma_G^m$, such that $\mathbf{f} = \mathbf{f}_U$ on a neighbourhood of C . In the case where C is a subpolyhedron of X the relative version can be easily obtained using the semisimplicial techniques described above.

3.13 Either for historical reasons or in order to have at our disposal explicit models for BG_m , which should make the exposition and the intuition easier in the rest of the text, we used Milnor’s heuristic semisimplicial approach. However the existence of BG_m can be deduced from Brown’s theorem [Brown 1962] on representable functors. This was observed for the first time by Arnold Shapiro. The reader who is interested in this approach is referred to [Kirby–Siebenmann 1977; IV section 8]. Siebenmann observes [ibidem, footnote p. 184] that Brown’s proof reduces the unproven statement at the end of 3.10 to an easy exercise. This is true. Let T be a representable homotopy cofunctor defined on the category of pointed CW–complexes. An easy inspection of Brown’s argument ensures that, provided $T(S^n)$ is countable for every $n \geq 0$, T admits a classifying CW–complex which is countable. Now let Y be a path connected CW–complex whose homotopy groups are all countable, and consider $T(X) := [X, Y]$. Then the above observation tells us that $T(X)$ admits a countable classifying Y' . But Y is homotopically equivalent to Y' by the homotopy uniqueness of classifying spaces, which proves what we wanted.

3.14 BG_m as a Grassmannian

We will start by constructing a particular model of EG_m . Let \mathbb{R}^∞ denote the union $\mathbb{R}^1 \subset \mathbb{R}^2 \subset \mathbb{R}^3 \subset \dots$

An m –microbundle ξ/Δ^k is said to be a *submicrobundle* of $\Delta^k \times \mathbb{R}^\infty$ if $E(\xi) \subset \Delta^k \times \mathbb{R}^\infty$ and the following diagram commutes:

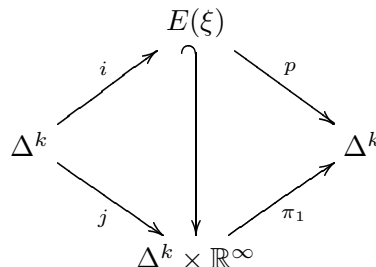

where i is the zero-section of ξ , p is the projection and $j(x) = (x, 0)$. Having said that, let WG_m be the ss–set whose typical k –simplex is a *monomorphism*

$$\mathbf{f}: \Delta^k \times \mathbb{R}^m \rightarrow \Delta^k \times \mathbb{R}^\infty$$

ie, a G_m micro-isomorphism between $\Delta^k \times \mathbb{R}^m$ and a submicrobundle of $\Delta^k \times \mathbb{R}^\infty$. The semisimplicial operators are defined as usual, passing to the induced micro-isomorphism.

Exercise WG_m is contractible.

In order to complete the exercise we need to show that each ss-map $\dot{\Delta} \rightarrow WG_m$ extends to $\Delta \rightarrow WG_m$, where Δ is any standard simplex. This means that each monomorphism $h: \dot{\Delta} \times \mathbb{R}^m \rightarrow \dot{\Delta} \times \mathbb{R}^\infty$ has to extend to a monomorphism $H: \Delta \times \mathbb{R}^m \rightarrow \Delta \times \mathbb{R}^\infty$ and this is not difficult to establish. \square

In the same way one can verify that WG_m satisfies the Kan condition. WG_m is called the G_m -Stiefel manifold.

An action $WG_m \times G_m \rightarrow WG_m$ defined by composing the micro-isomorphisms transforms WG_m into the space of a principal fibration

$$\gamma(G_m): G_m \rightarrow WG_m \rightarrow BG_m. \quad (3.14.1)$$

By the Steenrod's recognition criterion, BG_m in (3.14.1) is a classifying space for G_m and a typical k -simplex of BG_m is nothing but a G_m -submicrobundle of $\Delta^k \times \mathbb{R}^\infty$. In this way BG_m is presented as a *semisimplicial grassmannian*. Furthermore the *tautological* microbundle γ_G^m/BG_m is obtained by putting on the simplex σ the microbundle which it represents which we will still denote with σ . Therefore

$$\gamma_G^m|_\sigma := \sigma.$$

3.15 The ss-set Top_m/PL_m

In the case of the natural map of grassmannians

$$BPL_m \xrightarrow{p_m} BTop_m$$

induced by the inclusion $PL_m \subset Top_m$, it is very convenient to have a geometric description of its homotopic fibre. This is very easy to obtain using the semisimplicial language. In fact there is an action also defined by composition,

$$WTop_m \times PL_m \rightarrow WTop_m,$$

whose orbit space has the same homotopy type as BPL_m and gives the required fibration

$$\mathcal{B}: Top_m/PL_m \longrightarrow BPL_m \xrightarrow{p_m} BTop_m.$$

This takes us back to the general construction of Corollary 3.7.

Obviously, Top_m/PL_m is the ss-set obtained by factoring with respect to the natural action of PL_m on Top_m , so, by Observation 3.7, Top_m/PL_m satisfies the Kan condition and

$$\text{PL}_m \subset \text{Top}_m \rightarrow \text{Top}_m/\text{PL}_m$$

is a Kan fibration.

4 PL structures on topological microbundles

In this section we will consider the problem of the *reduction* of a topological microbundle to a PL microbundle and we will classify reductions in terms of liftings on their classifying spaces. In this way we will put in place the foundations of the obstruction theory which will allow the use apparatus of homotopy theory for the problem of classifying the PL structures on a topological manifold.

4.1 A *structure of PL microbundle* on a topological m -microbundle ξ , with base an SS -set X , is an equivalence class of topological micro-isomorphisms $\mathbf{f}: \xi \rightarrow \eta$, where η/X is a PL microbundle. The equivalence relation is $\mathbf{f} \sim \mathbf{f}'$ if $\mathbf{f}' = \mathbf{h} \circ \mathbf{f}$, with \mathbf{h} a PL micro-isomorphism.

A structure of PL microbundle will also be called a PL_μ -structure (μ indicates a microbundle). More generally, an SS -set, $\text{PL}_\mu(\xi)$, is defined so that a typical k -simplex is an equivalence class of micro-isomorphisms

$$\mathbf{f}: \Delta^k \times \xi \rightarrow \eta$$

where η is a PL m -microbundle on $\Delta^k \times X$. The semisimplicial operators are defined, as usual, passing to the induced micro-isomorphism.

Equivalently, a structure of PL microbundle on

$$\xi: X \xrightarrow{i} E(\xi) \xrightarrow{p} X$$

is a polyhedral structure Θ , defined on an open neighbourhood U of $i(X)$, such that

$$X \xrightarrow{i} U_\Theta \xrightarrow{p} X$$

is a (locally trivial) PL m -microbundle. If Θ' is another such polyhedral structure then we say that Θ is *equal* to Θ' if the two structures define the same germ in a neighbourhood of the zero-section, ie, if $\Theta = \Theta'$ in an open neighbourhood of $i(X)$ in $E(\xi)$. Then Θ truly represents an equivalence class. Using this language $\text{PL}_\mu(\xi)$ is the SS -set whose typical k -simplex is the germ around $\Delta^k \times X$ of a PL structure on the product microbundle $\Delta^k \times \xi$.

Going back to the fibration

$$\mathcal{B}: \text{Top}_m/\text{PL}_m \longrightarrow \text{BPL}_m \xrightarrow{p_m} \text{BTop}_m$$

constructed in 3.15 we fix, once and for all, a classifying map $\mathbf{f}: \xi \rightarrow \gamma_{\text{Top}}^m$, which restricts to a continuous map $f: X \rightarrow \text{BTop}_m$. Let us also fix a classifying map $\mathbf{p}_m: \gamma_{\text{PL}}^m \rightarrow \gamma_{\text{Top}}^m$, with restriction $p_m: \text{BPL}_m \rightarrow \text{BTop}_m$. A k -simplex of the KSS -set $\text{Lift}(f)$ is a continuous map

$$\sigma: \Delta^k \times X \rightarrow \text{BPL}_m$$

such that $p_m \circ \sigma = f \circ \pi_2$, where π_2 is the projection on X . Therefore a 0-simplex of $\text{Lift}(f)$ is nothing but a *lifting* of f to $B\text{PL}_m$, a 1-simplex is a *vertical homotopy class* of such liftings, etc. As usual the liftings are nothing but sections. In fact, passing to the induced fibration $f^*(\mathcal{B})$ (which we will denote later either with ξ_f or $\xi[\text{Top}_m/\text{PL}_m]$) we have, giving the symbols the obvious meanings,

$$\text{Lift}(f) \approx \text{Sect } \xi[\text{Top}_m/\text{PL}_m] \tag{4.1.1}$$

where the right hand side is the SS-set of sections of the fibration $\xi[\text{Top}_m/\text{PL}_m]$ associated with ξ .

Classification theorem for the PL_μ -structures *Using the notation introduced above, there is a homotopy equivalence*

$$\alpha: \text{PL}_\mu(\xi) \rightarrow \text{Lift}(f)$$

which is well defined up to homotopy.

First we will give an indication of how α can be constructed directly, following [Lashof 1971].

First proof Firstly we will observe that $\mathbf{f}: \xi \rightarrow \gamma_{\text{Top}}^m$ induces an isomorphism $\mathbf{h}: \xi \rightarrow f^*(\gamma_{\text{Top}}^m)$.

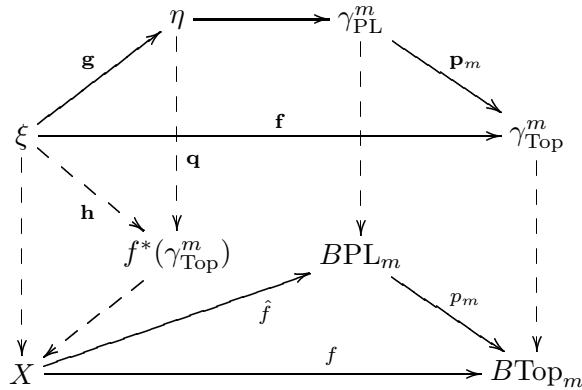

Let $\hat{f}: X \rightarrow B\text{PL}_m$ be a lifting of f and $\eta = \hat{f}^*(\gamma_{\text{PL}})$. The map of m -microbundles \mathbf{p}_m induces an isomorphism

$$\mathbf{q}: \eta = \hat{f}^*(\gamma_{\text{PL}}) \rightarrow f^*(\gamma_{\text{Top}}).$$

In fact, $f^*(\gamma_{\text{Top}}) = (p_m \hat{f})^*(\gamma_{\text{Top}}) = \hat{f}^* p_m^*(\gamma_{\text{Top}})$ and there is a canonical isomorphism φ between γ_{PL} and $p_m^*(\gamma_{\text{Top}})$. Therefore it will suffice to put

$$\mathbf{q} := \hat{f}^*(\varphi).$$

Now we can define a PL_μ -structure \mathbf{g} on ξ by defining

$$\mathbf{g} := \mathbf{q}^{-1}\mathbf{h}.$$

In this way we have associated a 0-simplex of $PL_\mu(\xi)$ with a 0-simplex of $Lift(f)$.

On the other hand, if \hat{f}_t is a 1-simplex of $Lift(f)$, ie, a vertical homotopy class of liftings of f , then the set of induced bundles $\hat{f}_t^*(\gamma_{Top})$ determines, in the way we described above, a 1-simplex \mathbf{g}_t of PL_μ -structures on ξ .

Conversely, fix a PL_μ -structure $\mathbf{g}: \xi \rightarrow \eta$, and let $\mathbf{a}: \eta \rightarrow \gamma_{PL}$ be a classifying map which covers $a: X \rightarrow BPL_m$.

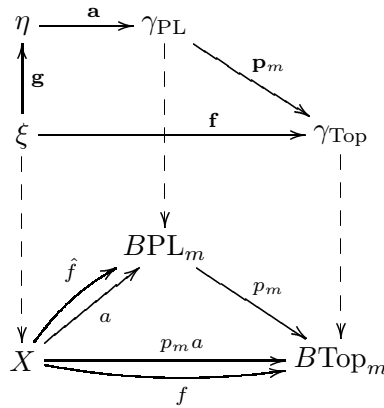

The maps $X \rightarrow BTop_m$ given by $p_m a$ and f are homotopic, since they classify topologically isomorphic microbundles. Therefore, since p_m is a fibration and $p_m a$ lifts to a trivially, then f also lifts to a $\hat{f}: X \rightarrow BPL_m$. This way is established a correspondence between a 0-simplex of $PL_\mu(\xi)$ and a 0-simplex of $Lift(f)$.

4.2 It would be possible to conclude the proof of the theorem in this heuristic way, however we would rather use a less direct argument, which is more elegant and, in some sense, more instructive and illuminating. This argument is due to [Kirby–Siebenmann 1977, pp. 236–239].



Preface If A and B are metrisable topological spaces, then the typical k -simplex of the SS of the functions B^A is a continuous map

$$\Delta^k \times A \rightarrow B.$$

The semisimplicial operators are defined by composition of functions. Naturally the path components of B^A are nothing but the homotopy classes $[A, B]$. An

SS-map g of a simplicial complex Y in B^A is a continuous map $G: Y \times A \rightarrow B$, defined by

$$G(y, a) = g(y)(a)$$

for $y \in Y$; furthermore g is homotopic to a constant if and only if G is homotopic to a map of the same type as

$$Y \times A \xrightarrow{\pi_2} A \longrightarrow B.$$

Incidentally we notice that if A has a countable system of neighbourhoods and if we give B^A the compact open topology, then g is continuous if and only if G is continuous.

Second proof of theorem 4.1 Let $\mathbf{M}_{\text{Top}}(X)$ be the SS-set whose typical k -simplex is a topological m -microbundle ξ with base $\Delta^k \times X$. In order to avoid set-theoretical problems we can think of ξ as being represented by a submicrobundle of $\Delta^k \times X \times \mathbb{R}^\infty$. We agree that another such microbundle $\xi'/\Delta^k \times X$ represents the same simplex of $\mathbf{M}_{\text{Top}}(X)$ if ξ coincides with ξ' in a neighbourhood of the zero-section. In practice (cf 3.14) $\mathbf{M}_{\text{Top}}(X)$ can be considered as the *grassmannian* of the m -microbundles on X . Now, if Y is a simplicial complex, then an SS-map $Y \rightarrow \mathbf{M}_{\text{Top}}(X)$ is represented by an m -microbundle γ on $Y \times X$ and it is homotopic to a constant if there exists an m -microbundle γ_I on $I \times Y \times X$, such that $\gamma_I|0 \times Y \times X = \gamma$ and $\gamma_I|1 \times Y \times X = Y \times \gamma_1$, where γ_1 is some microbundle on X .

Further, let $\mathbf{M}_{\text{Top}}^+(X)$ be the SS-set whose typical k -simplex is an equivalence class of pairs (ξ, \mathbf{f}) , where ξ is an m -microbundle on $\Delta^k \times X$ and $\mathbf{f}: \xi \rightarrow \gamma_{\text{Top}}^m$ is a classifying micro-isomorphism and, also, $(\xi, \mathbf{f}) \sim (\xi', \mathbf{f}')$ if the pairs are identical in a neighbourhood of the two respective zero-sections. In this case an SS-map $g: Y \rightarrow \mathbf{M}_{\text{Top}}^+(X)$ is represented by an m -microbundle η on $Y \times X$, together with a classifying map $\mathbf{f}_\eta: \eta \rightarrow \gamma_{\text{Top}}^m$. Furthermore g is homotopic to a constant if there exist an m -microbundle η_I on $I \times Y \times X$ and a classifying map $\mathbf{F}: \eta_I \rightarrow \gamma_{\text{Top}}^m$, such that $(\eta_I, \mathbf{F})|0 \times Y \times X = (\eta, \mathbf{f}_\eta)$ and $(\eta_I, \mathbf{F})|1 \times Y \times X$ is of type $(Y \times \eta_1, \mathbf{f}_1 \pi_2)$, where π_2 is the projection on η_1/X and \mathbf{f}_1 is a classifying map for η_1 . Consider the two forgetful maps

$$\mathbf{M}_{\text{Top}}(X) \xleftarrow{\rho_{\text{Top}}} \mathbf{M}_{\text{Top}}^+(X) \xrightarrow{\sigma_{\text{Top}}} B\text{Top}_m^X,$$

$\rho_{\text{Top}}(\xi, \mathbf{f}) = \xi$, and $\sigma_{\text{Top}}(\xi, \mathbf{f}) = f$. We leave to the reader the proof that ρ, σ are *homotopy equivalences*, since they induce a bijection between the path components, as well as an isomorphism between the homotopy groups of the corresponding components. For ρ this is a consequence of the classification theorem for topological m -microbundles, *in its relative version*. In order to find a homotopy inverse for σ , we instead use the construction of the induced bundle and of the homotopy theorem for microbundles. In the PL case we have analogous SS-sets and homotopy equivalences, which are defined in the same way as the corresponding topological objects:

$$\mathbf{M}_{\text{PL}}(X) \xleftarrow{\rho_{\text{PL}}} \mathbf{M}_{\text{PL}}^+(X) \xrightarrow{\sigma_{\text{PL}}} B\text{PL}_m^X,$$

where k -simplex of $\mathbf{M}_{\text{PL}}(X)$ is now a *topological m -microbundle* ξ on $\Delta^k \times X$, together with a PL structure Θ , and $(\xi, \Theta) \sim (\xi', \Theta')$ if such pairs coincide in a neighbourhood of the zero section.

We observe that the proof of the fact that σ_{PL} is a homotopy equivalence requires the use of Zeeman's simplicial approximation theorem.

In this way we obtain a commutative diagram of *forgetful* SS-maps

$$\begin{array}{ccccc}
 \mathbf{M}_{\text{PL}}(X) & \xleftarrow{\rho_{\text{PL}}} & \mathbf{M}_{\text{PL}}^+(X) & \xrightarrow{\sigma_{\text{PL}}} & \mathbf{BPL}_m^X \\
 \downarrow p' & & \downarrow p & & \downarrow p'' \\
 \mathbf{M}_{\text{Top}}(X) & \xleftarrow{\rho_{\text{Top}}} & \mathbf{M}_{\text{Top}}^+(X) & \xrightarrow{\sigma_{\text{Top}}} & \mathbf{BTop}_m^X
 \end{array}$$

where p'' is induced by the projection $p_m : \mathbf{BPL}_m \rightarrow \mathbf{BTop}_m$ of the fibration \mathcal{B} . It is easy to verify that both p' and p'' are Kan fibrations. Furthermore we can assume that p also is a fibration. In fact, if it is not, the Serre's trick makes p a fibration, transforming the diagram above into a new diagram which is *commutative up to homotopy* and where the horizontal morphisms are still homotopy equivalences, while the lateral vertical morphisms p', p'' remain unchanged. At this point the *Proposition 1.7* ensures that, if $(\xi, \mathbf{f}) \in \mathbf{M}_{\text{Top}}^+(X)$, then the fibre $p'^{-1}(\xi)$ is homotopically equivalent to the fibre $(p'')^{-1}(f)$. However, by definition:

$$\begin{aligned}
 (p')^{-1}(\xi) &= \text{PL}_\mu(\xi) \\
 (p'')^{-1}(f) &= \text{Lift}(f).
 \end{aligned}$$

The theorem is proved. □



Part III : The differential

1 Submersions

In this section we will introduce topological and PL submersions and we will prove that each closed submersion with compact fibres is a locally trivial fibration.

We will use Γ to stand for either Top or PL and we will suppose that we are in the category of Γ -manifolds without boundary.

1.1 A Γ -map $p: E^k \rightarrow X^l$ between Γ -manifolds is a Γ -*submersion* if p is locally the projection $\mathbb{R}^k \xrightarrow{\pi_l} \mathbb{R}^l$ on the first l -coordinates. More precisely, $p: E \rightarrow X$ is a Γ -submersion if there exists a commutative diagram

$$\begin{array}{ccc}
 E & \xrightarrow{p} & X \\
 \phi_y \uparrow & & \phi_x \uparrow \\
 U_y & & U_x \\
 \cap & & \cap \\
 \mathbb{R}^k & \xrightarrow{\pi_l} & \mathbb{R}^l
 \end{array}$$

where $x = p(y)$, U_y and U_x are open sets in \mathbb{R}^k and \mathbb{R}^l respectively and ϕ_y , ϕ_x are charts around x and y respectively.

It follows from the definition that, for each $x \in X$, the *fibre* $p^{-1}(x)$ is a Γ -manifold.

1.2 The link between the notion of submersions and that of bundles is very straightforward. A Γ -map $p: E \rightarrow X$ is a *trivial Γ -bundle* if there exists a Γ -manifold Y and a Γ -isomorphism $f: Y \times X \rightarrow E$, such that $pf = \pi_2$, where π_2 is the projection on X .

More generally, $p: E \rightarrow X$ is a *locally trivial Γ -bundle* if each point $x \in X$ has an open neighbourhood restricted to which p is a trivial Γ -bundle.

Even more generally, $p: E \rightarrow X$ is a Γ -*submersion* if each point y of E has an open neighbourhood A , such that $p(A)$ is open in X and the restriction $A \rightarrow p(A)$ is a trivial Γ -bundle.

Note A submersion is not, in general, a bundle. For example consider $E = \mathbb{R}^2 - \{0\}$, $X = \mathbb{R}$ and p projection on the first coordinate.

1.3 We will now introduce the notion of a product chart for a submersion. If $p: E \rightarrow X$ is a Γ -submersion, then for each point y in E , there exist a Γ -manifold U , and an open neighbourhood S of $x = p(y)$ in X and a Γ -embedding

$$\varphi: U \times S \rightarrow E$$

such that $\text{Im } \varphi$ is a neighbourhood of y in E and, also, $p \circ \varphi$ is the projection $U \times S \rightarrow S \subset E$. Therefore, as we have already observed, $p^{-1}(x)$ is a Γ -manifold. Let us now assume that φ satisfies further properties:

- (a) $U \subset p^{-1}(x)$
- (b) $\varphi(u, x) = u$ for each $u \in U$.

Then we can use interchangeably the following terminology:

- (i) the embedding φ is *normalised*
- (ii) φ is a *product chart* around U for the submersion p
- (iii) φ is a *tubular neighbourhood* of U in E with *fibre* S with respect to the submersion p .

The second is the most suitable and most commonly used.

With this terminology, $p: E \rightarrow X$ is a Γ -bundle if, for each $x \in X$, there exists a product chart $\varphi: p^{-1}(x) \times S \rightarrow E$ around the fibre $p^{-1}(x)$, such that the image of φ coincides with $p^{-1}(S)$.

1.4 The fact that many submersions are fibrations is a consequence of the fundamental isotopy extension theorem, which we will state here in the version that is more suited to the problem that we are tackling.

Let V be an open set in the Γ -manifold X , Q another Γ -manifold which acts as the *parameter space* and let us consider an isotopy of Γ -embeddings

$$G: V \times Q \rightarrow X \times Q.$$

Given a compact subset C of V and a point q in Q , we are faced with the problem of establishing if and when there exists a neighbourhood S of q in Q and an ambient isotopy $G': X \times S \rightarrow X \times S$, which extends G on C , ie $G' | C \times S = G | C \times S$.

Isotopy extension theorem *Let $C \subset V \subset X$ and $G: V \times Q \rightarrow X \times Q$ be defined as above. Then there exists a compact neighbourhood C_+ of C in V and an extension G' of G on C , such that the restriction of G' to $(X - C_+) \times S$ is the identity. \square*

This remarkable result for the case $\Gamma = \text{Top}$ is due to [Černavskii 1968], [Lees 1969], [Edwards and Kirby 1971], [Siebenmann 1972].

For the case $\Gamma = \text{PL}$ instead we have to thank [Hudson and Zeeman 1964] and [Hudson 1966]. A useful bibliographical reference is [Hudson 1969].

Note In general, there is no way to obtain an extension of G to the whole open set V . Consider, for instance, $V = \mathring{D}^m$, $X = \mathbb{R}^m$, $Q = \mathbb{R}$ and

$$G(v, t) = \left(\frac{v}{1 - t\|v\|}, t \right)$$

for $t \in Q$ and $v \in \mathring{D}^m$ and $t \in [0, 1]$, and $G(v, t)$ stationary outside $[0, 1]$. For $t = 1$, we have

$$G_1(\mathring{D}^m) = \mathbb{R}^m.$$

Therefore G_1 does not extend to any homeomorphism $G'_1: \mathbb{R}^m \rightarrow \mathbb{R}^m$, and therefore G does not admit any extension on V .

1.5 Let us now go back to submersions. We have to establish two lemmas, of which the first is a direct consequence of the isotopy extension theorem.

Lemma *Let $p: Y \times X \rightarrow X$ be the product Γ -bundle and let $x \in X$. Further let $U \subset Y_x = p^{-1}(x)$ be a bounded open set and $C \subset U$ a compact set. Finally, let*

$$\varphi: U \times S \rightarrow Y_x \times X$$

be a product chart for p around U . Then there exists a product chart

$$\varphi_1: Y_x \times S_1 \rightarrow Y_x \times X$$

for the submersion p around the whole of Y_x , such that

- (a) $\varphi = \varphi_1$ on $C \times S_1$
- (b) $\varphi_1 =$ the identity outside $C_+ \times S_1$, where, as usual, C_+ is a compact neighbourhood of C in U .

Proof Apply the isotopy extension theorem with X , or better still S , as the space of the parameters and Y_x as ambient manifold. \square

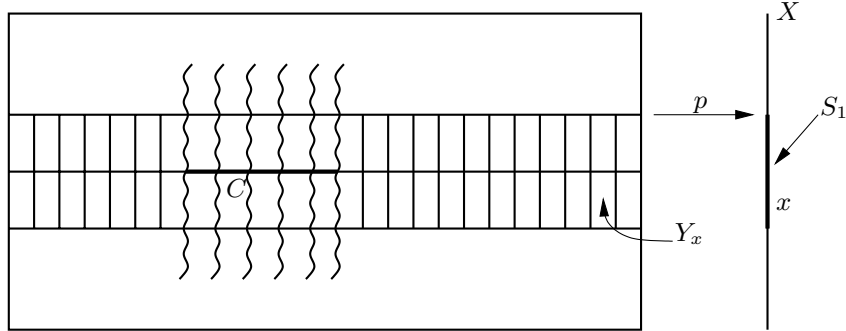

Glueing Lemma Let $p: E \rightarrow X$ be a submersion, $x \in X$, with C and D compact in $p^{-1}(x)$. Let U, V be open neighbourhoods of C, D in $p^{-1}(x)$; let $\varphi: U \times S \rightarrow E$ and $\psi: V \times S \rightarrow E$ be products charts. Then there exists a product chart $\omega: M \times T \rightarrow E$, where M is an open neighbourhood of $C \cup D$ in $p^{-1}(x)$. Furthermore, we can chose ω such that $\omega = \varphi$ on $C \times T$ and $\omega = \psi$ on $(D - U) \times T$.



Proof Let $C_+ \subset U$ and $D_+ \subset V$ be compact neighbourhoods of C, D in $p^{-1}(x)$.

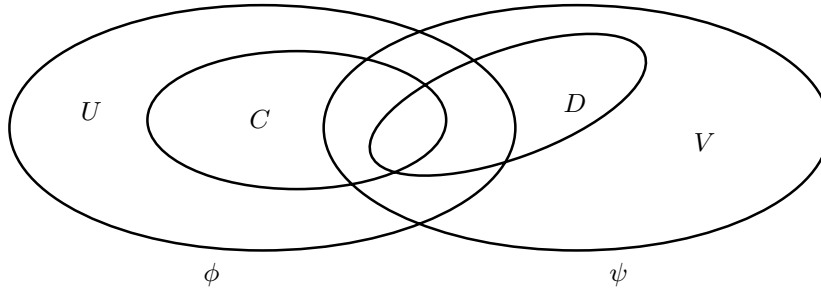

Applying the lemma above to $V \times X \rightarrow X$ we deduce that there exists a product chart for p around V

$$\psi_1: V \times S_1 \rightarrow E$$

such that

- (a) $\psi_1 = \psi$ on $(V - U) \times S_1$
- (b) $\psi_1 = \varphi$ on $(C_+ \cap D_+) \times S_1$

Let $M_1 = \overset{\circ}{C}_+ \cup \overset{\circ}{D}_+$ and $T_1 = S \cap S_1$ and define

$$\omega: M_1 \times T_1 \rightarrow E$$

by putting

$$\omega | \overset{\circ}{C}_+ \times T_1 = \varphi | \overset{\circ}{C}_+ \times T_1 \quad \text{and} \quad \omega | \overset{\circ}{D}_+ \times T_1 = \psi_1 | \overset{\circ}{D}_+ \times T_1$$

Essentially, this is the required product chart. Since ω is obtained by glueing two product charts, it suffices to ensure that ω is injective. It may not be injective but it is locally injective by definition and furthermore, $\omega|_{M_1}$ is injective, being equal to the inclusion $M_1 \subset p^{-1}(x)$. Now we restrict ω firstly to the interior of a compact neighbourhood of $C \cup D$ in M_1 , let us say M . Once this has been done it will suffice to show that there exists a neighbourhood T of x in X , contained in T_1 , such that $\omega|_{M \times T_1}$ is injective. The existence of such a T_1 follows from a standard argument, see below. This completes the proof. \square

The standard argument which we just used is the same as the familiar one which establishes that, if $N \subset A$ are differential manifolds, with N compact and $E(\varepsilon)$ is a small ε -neighbourhood of the zero-section of the normal vector bundle of N in A , then a diffeomorphism between $E(\varepsilon)$ and a tubular neighbourhood of N in A is given by the exponential function, which is locally injective on $E(\varepsilon)$.

▲

Theorem (Siebenmann) *Let $p: E \rightarrow X$ be a closed Γ -submersion, with compact fibres. Then p is a locally trivial Γ -bundle.*

Proof The glueing lemma, together with a finite induction, ensures that, if $x \in X$, then there exists a product chart

$$\varphi: p^{-1}(x) \times S \rightarrow E$$

around $p^{-1}(x)$. The set $N = p(E - \text{Im } \varphi)$ is closed in X , since p is a closed map. Furthermore N does not contain x . If $S_1 = S - (X - N)$, then the restricted chart $p^{-1}(x) \times S_1 \rightarrow E$ has image equal to $p^{-1}(S_1)$. In fact, when $p(y) \in S_1$, we have that $p(y) \notin N$ and therefore $y \in \text{Im } \varphi$. This ends the proof of the theorem. \square

We recall that a continuous map between metric spaces and with compact fibres, is closed if and only if it is proper, ie, if the preimage of each compact set is compact.

1.6 Submersions $p: E \rightarrow X$ between manifolds with boundary

Submersions between manifolds with boundary are defined in the same way and the theory is developed in an analogous way to that for manifolds without boundary. The following changes apply:

- (a) for $i = k, l$ in 1.1, we substitute $\mathbb{R}_+^i \equiv \{x_1 \geq 0\}$ for \mathbb{R}^i
- (b) in 1.4 the isotopy $G_t: V \rightarrow X$ must be *proper*, ie, formed by embeddings onto open subsets of X (briefly, G_t must be an isotopy of *open embeddings*).

Addendum to the isotopy extension lemma 1.4 *If $Q = I^n$, then we can take S to be the whole of Q .*

Note Even in the classical case $Q = [0, 1]$ the extension of the isotopy cannot, in general, be on the whole of V . For example the isotopy $G(v, t): \mathring{D}^m \times I \rightarrow \mathbb{R}^m \times I$ of note 1.4, ie,

$$G(v, t) = \left(\frac{v}{1 - t\|v\|}, t \right),$$

with $t \in [0, 1]$, connects the inclusion $\mathring{D}^m \subset \mathbb{R}^m (t = 0)$ with G_1 , which cannot be extended. A fortiori, G cannot be extended.

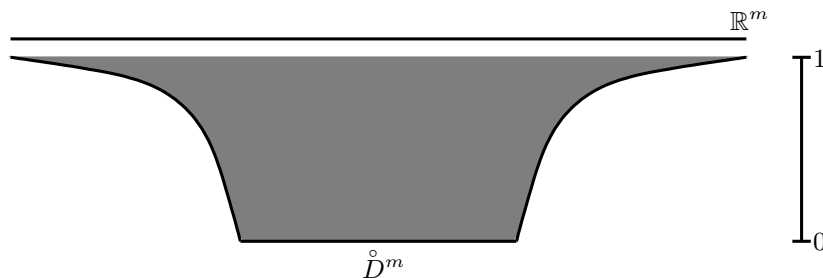

1.7 Differentiable submersions

These are much more familiar objects than the topological ones. Changing the notation slightly, a differentiable map $f: X \rightarrow Y$ between manifolds without boundary is a *submersion* if it verifies the conditions in 1.1 and 1.2, taking now $\Gamma = \text{Diff}$. However the following *alternative definition* is often used: f is a submersion if its differential is surjective for each point in X .

Theorem *A proper submersion, with compact fibres, is a differentiable bundle.*

Proof For each $y \in Y$, a sufficiently small tubular neighbourhood of $p^{-1}(y)$ is the required product chart. □

1.8 As we saw in 1.2 there are simple examples of submersions with non-compact fibres which are not fibrations.

We now wish to discuss a case which is remarkable for its content and difficulty. This is a case where a submersion with non-compact fibres is a submersion. This result has a central role in the theorem of classification of PL structures on a topological manifold.

Let Δ be a simplex or a cube and let M^m be a topological manifold without boundary which is not necessarily compact and let also Θ be a PL structure on $\Delta \times M$ such that the projection

$$p: (\Delta \times M)_\Theta \rightarrow \Delta$$

is a PL submersion.

Fibration theorem (Kirby–Siebenmann 1969) *If $m \neq 4$, then p is a PL bundle (necessarily trivial).*

Before starting to explain the theorem’s intricate line of the proof we observe that in some sense it might appear obvious. It is therefore symbolic for the hidden dangers and the possibilities of making a blunder found in the study of the interaction between the combinatorial and the topological aspects of manifolds. Better than any of my efforts to represent, with inept arguments, the uneasiness caused by certain idiosyncrasies is an outburst of L Siebenmann, which is contained in a small note of [Kirby–Siebenmann 1977, p. 217], which is referring exactly to the fibration theorem:

“This modest result may be our largest contribution to the final classification theorem; we worked it out in 1969 in the face of a widespread belief that it was irrelevant and/or obvious and/or provable for all dimensions (cf [Mor₃], [Ro₂] and the 1969 version of [Mor₄]). Such a belief was not so unreasonable since 0.1 is obvious in case M is compact: every proper CAT submersion is a locally trivial bundle”.
(L Siebenmann)

▼

Proof We will assume $\Delta = I$. The general case is then analogous with some more technical detail. We identify M with $0 \times M$ and observe that, since p is a submersion, then Θ restricts to a PL structure on $M = p^{-1}(0)$. This enables us to assume that M is a PL manifold. We filter M by means of an ascending chain

$$M_0 \subset M_1 \subset M_2 \subset \dots \subset M_i \subset \dots$$

of PL compact m -submanifolds, such that each M_i is in a regular neighbourhood of some polyhedron contained in M and, furthermore, $M_i \subset \overset{\circ}{M}_{i+1}$ and $M = \cup_i M_i$. Such a chain certainly exists. Furthermore, since M_i is a regular neighbourhood, its frontier \dot{M}_i is PL bicollared in M and we can take open disjoint PL bicollars $V_i \approx \dot{M}_i \times \mathbb{R}$, such that $V_i \cap M_i = M_i \times (-\infty, 0]$. Let us fix an index i and, for the sake simplicity, we will write N instead of M_i . We will work in $E = (I \times \dot{N} \times \mathbb{R})_{\Theta}$, equipped with Cartesian projections.

The reader can observe that, even if $I \times \dot{N}$ is a PL manifold with the PL manifold structure coming from M , it is not, a priori, a PL submanifold of E . It is exactly this situation that creates some difficulties which will force us to avoid the dimension $m = 4$.

$$\begin{array}{ccc} E & \xrightarrow{p} & I \\ \pi \downarrow & & \\ \mathbb{R} & & \end{array}$$

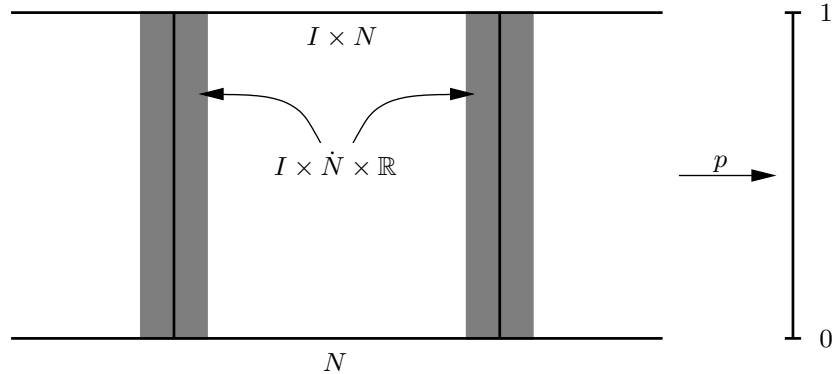

1.8.1 First step

We start by recalling the engulfing theorem proved in I.4.11:

Theorem *Let W^w be a closed topological manifold with $w \neq 3$, let Θ be a PL structure on $W \times \mathbb{R}$ and $C \subset W \times \mathbb{R}$ a compact subset. Then there exists a PL isotopy G of $(W \times \mathbb{R})_\Theta$ having compact support and such that $G_1(C) \subset W \times (-\infty, 0]$.*

The theorem tells us that the tide, which rises in a PL way, swamps every compact subset of $(W \times \mathbb{R})_\Theta$, even if W is not a PL manifold.

Corollary (Engulfing from below) *For each $\lambda \in I$ and for each pair of integers $a < b$, there exists a PL isotopy with compact support*

$$G_t: (\lambda \times \dot{N} \times \mathbb{R})_\Theta \rightarrow (\lambda \times \dot{N} \times \mathbb{R})_\Theta$$

such that

$$G_1(\lambda \times \dot{N} \times (-\infty, a)) \supset \lambda \times \dot{N} \times (-\infty, b]$$

provided that $m \neq 4$.

The proof is immediate. □

1.8.2 Second step (Local version of engulfing from below)

By theorem 1.5 each compact subset of the fibre of a submersion is contained in a product chart. Therefore, for each integer r and each point λ of I , there exists a product chart

$$\varphi: \lambda \times \dot{N} \times (-r, r) \times I_\lambda \rightarrow E$$

for the submersion p , where I_λ indicates a suitable open neighbourhood of λ in I . If $a \leq b$ are any two integers, then Corollary 1.8.1 ensures that r can be chosen such that $[a, b] \subset (-r, r)$ and also that there exists a PL isotopy,

$$G_t: \lambda \times \dot{N} \times (-r, r) \rightarrow \lambda \times \dot{N} \times (-r, r),$$

which engulfs level b inside level a and also has a compact support. Now let $f: I \rightarrow I$ be a PL map, whose support is contained in I_λ and is 1 on a neighbourhood of λ . We define a PL isotopy

$$H_t: E \rightarrow E$$

in the following way:

- (a) $H_t|_{\text{Im } \varphi}$ is determined by the formula

$$H_t(\varphi(x, \mu)) = \varphi(G_{f(\mu)t}(x), \mu)$$

where $x \in \lambda \times \dot{N} \times (-r, r)$ and $\mu \in I_\lambda$.

- (b) H_t is the identity outside $\text{Im } \varphi$.

It results that H_t is an isotopy of all of E which commutes with the projection p , ie, H_t is a spike isotopy.

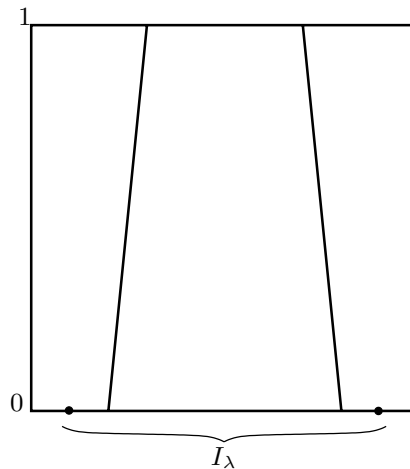

A possibilty for $f: I \rightarrow I$

The effect of H_t is that of including level b inside level a , at least as far as small a neighbourhood of λ .

1.8.3 Third step (A global spike version of the Engulfing form below)

For each pair of integers $a < b$, there exists a PL isotopy

$$H_t: E \rightarrow E,$$

which commutes with the projection p , has compact support and engulfs the level b inside the level a , ie,

$$H_1(I \times \dot{N} \times (-\infty, a)) \supset I \times \dot{N} \times (-\infty, b].$$

The proof of this claim is an instructive exercise and is therefore left to the reader. Note that I will have to be divided into a finite number of sufficiently small intervals, and that the isotopies of local spike engulfing provided by the step 1.8.2 above will have to be wisely composed.

1.8.4 Fourth step (The action of \mathbb{Z})

For each pair of integers $a < b$, there exists an open set $E(a, b)$ of E , which contains $\pi^{-1}[a, b]$ and is such that

$$p: E(a, b) \rightarrow I$$

is a PL bundle.

Proof Let $H_1: E \rightarrow E$ be the PL homeomorphism constructed in 1.8.3. Let us consider the compact set

$$C(a, b) = H_1(\pi^{-1}(-\infty, a]) \setminus \pi^{-1}(-\infty, a)$$

and the open set

$$E(a, b) = \bigcup_{n \in \mathbb{Z}} H_1^n(C(a, b)).$$

There is a PL action of \mathbb{Z} on $E(a, b)$, given by

$$\begin{aligned} q: \mathbb{Z} \times E(a, b) &\rightarrow E(a, b) \\ (1, x) &\mapsto H_1(x) \end{aligned}$$

This action commutes with p .

If $B = E(a, b)/\mathbb{Z}$ is the space of the orbits then we have a commutative diagram

$$\begin{array}{ccc} E(a, b) & \xrightarrow{q} & B \\ & \searrow p & \swarrow p' \\ & I & \end{array}$$

Since H_1 is PL, then B inherits a PL structure which makes q into a PL covering; therefore since p is a PL submersion, then p' also is a submersion. Furthermore each fibre of p' is compact, since it is the quotient of a compact set, and p' is closed. So p' is a PL bundle, and from that it follows that p also is such a bundle (some details have been omitted).

1.8.5 Fifth step (Construction of product charts around the manifolds M_i)

Until now we have worked with a given manifold $M_i \subset M$ and denoted it with N . Now we want to vary the index i . Step 1.8.4 ensures the existence of an open subset

$$E'_i \subset E_i = (I \times \dot{M}_i \times \mathbb{R})_{\Theta}$$

which contains $I \times \dot{M}_i \times 0$ such that it is a locally trivial PL bundle on I . We chose PL trivialisations

$$\begin{array}{ccc} h_i: I \times Y'_i & \xrightarrow{\approx} & E'_i \subset I \times V_i \\ & \searrow & \swarrow \\ & I & \end{array}$$

and we write M'_i for $Y'_i \cap M_i = Y'_i \cap (\dot{M}_i \times (-\infty, 0])$.

We define a PL submanifold X_i of $(I \times M)_{\Theta}$, by putting

$$X_i = \{(I \times M_i - E'_i) \cup h_i(I \times M'_i)\}_{\Theta}$$

and observe that $X_i \subset \overset{\circ}{X}_{i+1}$ and $\bigcup_i X_i = (I \times M)_{\Theta}$.

The projection $p_i : X_i \rightarrow I$ is a PL submersion and we can say that the whole proof of the theorem developed until now has only one aim: ensure for i the existence of a PL submersion of type p_i .

Now, since X_i is compact, the projection p_i is a locally trivial PL bundle and therefore we have trivialisations

$$\begin{array}{ccc} I \times M_i & \xrightarrow{g_i} & X_i \\ & \searrow & \swarrow p_i \\ & & I \end{array}$$

1.8.6 Sixth step (Compatibility of the trivialisations)

In general we cannot expect that g_i coincides with g_{i+1} on $I \times M_i$. However it is possible to alter g_{i+1} in order to obtain a new chart g'_{i+1} which is compatible with g_i . To this end let us consider the following commutative diagram

$$\begin{array}{ccccc} I \times M_{i+1} & \supset & I \times M_i & \xrightarrow{g_i} & X_i \subset (I \times M)_\Theta \\ & \searrow \Gamma_i & \downarrow \gamma_i & & \cap \\ & & I \times M_{i+1} & \xrightarrow{g_{i+1}} & X_{i+1} \subset (I \times M)_\Theta \end{array}$$

where all the maps are intended to be PL and they also commute with the projection on I . The map γ_i is defined by commutativity and Γ_i exists by the isotopy extension theorem of Hudson and Zeeman. It follows that

$$g'_{i+1} := g_{i+1} \Gamma_i$$

is the required compatible chart.

1.8.7 Conclusion

In light of 1.8.6. and of an infinite inductive procedure we can assume that the trivialisations $\{g_i\}$ are compatible with each other. Then

$$g := \bigcup_i g_i$$

is a PL isomorphism $I \times M_\Theta \approx (I \times M)_\Theta$, which proves the theorem. □



Note I advise the interested reader who wishes to study submersions in more depth, including also the case of submersions of stratified topological spaces, as well as other difficult topics related to the spaces of homomorphisms, to consult [Siebenmann, 1972].

To the reader who wishes to study in more depth the theorem of fibrations for submersions with non compact fibres, including extension theorems of sliced concordances, I suggest [Kirby–Siebemann 1977 Essay II].

2 The space of the PL structures on a topological manifold M

Let M^m be a topological manifold without boundary, which is not necessarily compact.

2.1 The complex $PL(M)$

The space $PL(M)$ of PL structures on M is the SS-set which has as typical k -simplex σ a PL structure Θ on $\Delta^k \times M$, such that the projection

$$(\Delta^k \times M)_\Theta \xrightarrow{\pi_1} \Delta^k$$

is a PL submersion. The semisimplicial operators are defined using fibred products. More precisely, if $\lambda: \Delta^l \rightarrow \Delta^k$ is in Δ^* , then $\lambda^\#(\sigma)$ is the PL structure on $\Delta^l \times M$, which is obtained by pulling back π_1 by λ :

$$\lambda^\#(\sigma) \left\{ \begin{array}{ccc} (\Delta^l \times M)_{\lambda^*\Theta} & \longrightarrow & (\Delta^k \times M)_\Theta \\ \pi_1 \downarrow & & \downarrow \pi_1 \\ \Delta^l & \xrightarrow{\lambda} & \Delta^k \end{array} \right.$$

An equivalent definition is that a k -simplex of $PL(M)$ is an equivalence class of commutative diagrams

$$\begin{array}{ccc} \Delta^k \times M & \xrightarrow{f} & Q \\ & \searrow \pi_1 & \swarrow p \\ & \Delta^k & \end{array}$$

where Q is a PL manifold, p a PL submersion, f a topological homeomorphism and the two diagrams are equivalent if $f' = \varphi \circ f$, where $\varphi: Q \rightarrow Q'$ is a PL isomorphism.

Under this definition a k -simplex of $PL(M)$ is a *sliced concordance* of PL structures on M .



In order to show the equivalence of these two definitions, let temporarily $PL'(M)$ (respectively $PL''(M)$) be the SS-set obtained by using the first (respectively the second) definition. We will show that there is a canonical semisimplicial isomorphism $\alpha: PL'(M) \rightarrow PL''(M)$. Define $\alpha(\Delta \times M)_\Theta$ to be the equivalence class of $Id: \Delta \times M \rightarrow (\Delta \times M)_\Theta$ where $\Delta = \Delta^k$. Now let $\beta: PL''(M) \rightarrow$

$\text{PL}'(M)$ be constructed as follows. Given $f: \Delta \times M \rightarrow Q_{PL}$, let Θ be a maximal PL atlas on Q_{PL} . Then set $\beta(f) := (\Delta \times M)_{f^*(\Theta)}$. The map β is well defined since, if f' is equivalent to f in $\text{PL}''(M)$, then

$$(\Delta \times M)_{f'^*\Theta'} = (\Delta \times M)_{(\phi \circ f)^*\Theta'} = (\Delta \times M)_{f^*\phi^*\Theta'} = (\Delta \times M)_{f^*\Theta}.$$

The last equality follows from the fact that ϕ is PL, hence $\phi^*\Theta' = \Theta$. Now let us prove that each of α and β is the inverse of the other. It is clear that $\beta \circ \alpha = \text{Id}_{\text{PL}'(M)}$. Moreover

$$\alpha \circ \beta(\Delta \times M \xrightarrow{f} Q) = \alpha(\Delta \times M)_{f^*\Theta} = (\Delta \times M \xrightarrow{\text{Id}} (\Delta \times M)_{f^*\Theta}).$$

But $f \circ \text{Id} = f: (\Delta \times M)_{f^*\Theta} \rightarrow Q$ is PL by construction, therefore $\alpha \circ \beta$ is the identity.

Since the submersion condition plays no relevant role in the proof, we have established that $\text{PL}'(M)$ and $\text{PL}''(M)$ are canonically isomorphic.

▲

Observations (a) If M is compact, we know that the submersion π_1 is a trivial PL bundle. In this case a k -simplex is a k -isotopy of structures on M . See also the next observation.

(b) (Exercise) If M is compact then the set $\pi_0(\text{PL}(M))$ of path components of $\text{PL}(M)$ has a precise geometrical meaning: two PL structures Θ, Θ' on M are in the same path component if and only if there exists a topological isotopy $h_t: M \rightarrow M$, with $h_0 = 1_M$ and $h_1: M_\Theta \rightarrow M_{\Theta'}$ a PL isomorphism. This is also true if M is non-compact and the dimension is not 4 (hint: use the fibration theorem).

(c) $\text{PL}(M) \neq \emptyset$ if and only if M admits a PL structure.

(d) If $\text{PL}(M)$ is contractible then M admits a PL structure and such a structure is strongly unique. This means that two structures Θ, Θ' on M are isotopic (or concordant). Furthermore any two isotopies (concordances) between Θ and Θ' can be connected through an isotopy (concordance respectively) with two parameters, and so on.

(e) If $m \leq 3$, Kerékjártó (1923) and Moise (1952, 1954) have proved that $\text{PL}(M)$ is contractible. See [Moise 1977].

2.2 The ss-set $\text{PL}(TM)$

Now we wish to define the space of PL structures on the tangent microbundle on M . In this case it will be easier to take as TM the microbundle

$$M \xrightarrow{\Delta} M \times M \xrightarrow{\pi_2} M,$$

where π_2 is the projection on the second factor. Hirsch calls this the *second* tangent bundle. This is obviously a notational convention since if we swap the factors we obtain a canonical isomorphism between the first and the second tangent bundle.

More generally, let, $\xi: X \xrightarrow{i} E(\xi) \xrightarrow{p} X$ be a topological m -microbundle on a topological manifold X . A *PL structure* Θ on ξ is a PL manifold structure on an open neighbourhood U of $i(X)$ in $E(\xi)$, such that $p: U_\Theta \rightarrow X$ is a PL submersion.

If Θ' is another PL structure on ξ , we say that Θ is *equal* to Θ' if Θ and Θ' define the same germ around the zero-section, ie, if $\Theta = \Theta'$ in some open neighbourhood of $i(X)$ in $E(\xi)$. Then Θ really represents an equivalence class.

Note A PL structure Θ on ξ is different from a PL microbundle structure on ξ , namely a PL_μ -structure, as it was defined in II.4.1. The former does *not* require that the zero-section $i: X \rightarrow U_\Theta$ is a PL map. Consequently $i(X)$ does not have to be a PL submanifold of U_Θ , even if it is, obviously, a topological submanifold.

The *space of the PL structures* on ξ , namely $\text{PL}(\xi)$, is the SS-set, whose typical k -simplex is the germ around $\Delta^k \times X$ of a PL structure on the product microbundle $\Delta^k \times \xi$. The semisimplicial operators are defined using the construction of the induced bundle.

Later we shall see that as far as the classification theorem is concerned the concepts of PL structures and PL_μ -structures on a topological microbundle are effectively the same, namely we shall prove (fairly easily) that the SS-sets $\text{PL}(\xi)$ and $\text{PL}_\mu(\xi)$ have the same homotopy type (proposition 4.8). However the former space adapts naturally to the case of smoothings (Part V) when there is no fixed PL structure on M .

Lemma $\text{PL}(M)$ and $\text{PL}(TM)$ are KSS-sets.

Proof This follows by pulling back over the PL retraction $\Delta^k \rightarrow \Lambda^k$. □

3 Relation between $\text{PL}(M)$ and $\text{PL}(TM)$

From now on, unless otherwise stated, we will introduce a hypothesis, which is only apparently arbitrary, on our initial topological manifold M .

(*) We will assume that there is a PL structure *fixed* on M .

The arbitrariness of this assumption is in the fact that it is our intention to tackle jointly the two problems of *existence* and of the *classification* of the PL structures on M . However this preliminary hypothesis simplifies the exposition and makes the technique more clear, without invalidating the problem of the classification. Later we will explain how to avoid using (*), see section 5.

3.1 The differential

Firstly we define an ss-map

$$d: \text{PL}(M) \rightarrow \text{PL}(TM),$$

namely the *differential*, by setting, for $\Theta \in \text{PL}(M)^{(k)}$, $d\Theta$ to be equal to the PL structure $\Theta \times M$ on $E(\Delta^k \times TM) = \Delta^k \times M \times M$.

Our aim is to prove that the differential is a homotopy equivalence, except in dimension $m = 4$.

Classification theorem $d: \text{PL}(M) \rightarrow \text{PL}(TM)$ is a homotopy equivalence for $m \neq 4$.

The philosophy behind this result is that *infinitesimal* information contained in TM can be *integrated* in order to solve the classification problem on M . In other words d is used to *linearise* the classification problem.

The theorem also holds for $m = 4$ if none of the components of M are compact. However the proof uses results of [Gromov 1968] which are beyond the scope of this book.

We now set the stage for the proof of theorem 3.1.

3.2 The Mayer–Vietoris property

Let U be an open set of M . Consider the PL structure induced on U by the one fixed on M . The correspondences $U \rightarrow \text{PL}(U)$ and $U \rightarrow \text{PL}(TU)$ define contravariant functors from the category of the inclusions between open sets of M , with values in the category of ss-sets. Note that $TU = TM|_U$.

Notation We write $F(U)$ to denote either $\text{PL}(U)$ or $\text{PL}(TU)$ without distinction.

Lemma (Mayer–Vietoris property) *The functor F transforms unions into pullbacks, ie, the following diagram*

$$\begin{array}{ccc} F(U \cup V) & \longrightarrow & F(U) \\ \downarrow & & \downarrow \\ F(V) & \longrightarrow & F(U \cap V) \end{array}$$

is a pull back for each pair of open sets $U, V \subset M$.

The proof is an easy exercise. \square

3.3 Germs of structures

Let A be any subset of M . The functor F can then be extended to A using the germs. More precisely, we set

$$\begin{aligned} PL(A \subset M) &:= \varinjlim \{PL(U) : A \subset U \text{ open in } M\} \\ PL(TM|_A) &:= \varinjlim \{PL(TU) : A \subset U \text{ open in } M\}. \end{aligned}$$

The differential can also be extended to an ss-map

$$d_A: PL(A \subset M) \rightarrow PL(TM|_A)$$

which is still defined using the rule $\Theta \rightarrow \Theta \times U$.

Finally, the Mayer–Vietoris property 3.2 is still valid if, instead of open sets we consider closed subsets. This implies that, when we write $F(A)$ for either $PL(A \subset M)$ or $PL(TM|_A)$, then the diagram of restrictions

$$\begin{array}{ccc} F(A \cup B) & \longrightarrow & F(A) \\ \downarrow & & \downarrow \\ F(B) & \longrightarrow & F(A \cap B) \end{array} \tag{3.3.1}$$

is a pullback for closed $A, B \subset M$. \square

3.4 Note about base points

If $\Theta \in PL(M)^{(0)}$, ie, Θ is a PL structure on M , there is a canonical base point $*$ for the ss-set $PL(M)$, such that

$$*_k = \Delta^k \times \Theta.$$

In this way we can point each path component of $PL(M)$ and correspondingly of $PL(TM)$. Furthermore we can assume that d is a pointed map on each path component. The same thing applies more generally for $PL(A \subset M)$ and its related differential. In other words we can always assume that the diagram 3.3.1 is made up of ss-maps which are pointed on each path component.

4 Proof of the classification theorem

The method of the proof is based on immersion theory as viewed by Haefliger and Poenaru (1964) et al. Among the specialists, this method of proof has been named the *Haefliger and Poenaru machine* or the *immersion theory machine*. Various authors have worked on this topic. Among these we cite [Gromov 1968], [Kirby and Siebenmann 1969], [Lashof 1970] and [Rourke 1972].

There are several versions of the immersion machine tailored to the particular theorem to be proved. All versions have a common theme. We wish to prove that a certain (differential) map d connecting functors defined on manifolds, or more generally on germs, is a homotopy equivalence. We prove:

- (1) The functors satisfy a Mayer–Vietoris property (see for example 3.2 above).
- (2) The differential is a homotopy equivalence when the manifold is \mathbb{R}^n .
- (3) Restrictions to certain subsets are Kan fibrations.

Once these are established there is a transparent and automatic procedure which leads to the conclusion that d is a homotopy equivalence. This procedure could even be described with axioms in terms of categories. We shall not axiomatise the machine. Rather we shall illustrate it by example.

The versions differ according to the precise conditions and subsets used. In this section we apply the machine to prove theorem 3.1. We are working in the topological category and we shall establish (3) for arbitrary compact subsets. The Mayer–Vietoris property was established in 3.2. We shall prove (2) in sections 4.1–4.4 and (3) in section 4.5 and 4.6. The machine proof itself comes in section 4.7.

In the next part (IV.1) we shall use the machine for its original purpose, namely immersion theory. In this version, (3) is established for the restriction of X to X_0 where X is obtained from X_0 attaching one handle of index $< \dim X$.

The classification theorem for $M = \mathbb{R}^m$

4.1 The following proposition states that the function which restricts the PL structures to their germs in the origin is a homotopy equivalence in \mathbb{R}^m .

Proposition *If $M = \mathbb{R}^m$ with the standard PL structure, then the restriction $r: \text{PL}(\mathbb{R}^m) \rightarrow \text{PL}(0 \subset \mathbb{R}^m)$ is a homotopy equivalence.*

Proof We start by stating that, given an open neighbourhood U of 0 in \mathbb{R}^m , there always exist a homeomorphism ρ between \mathbb{R}^m and a neighbourhood of 0 contained in U , which is the identity on a neighbourhood of 0. There also exists an isotopy $H: I \times \mathbb{R}^m \rightarrow \mathbb{R}^m$, such that $H(0, x) = x$, $H(1, x) = \rho(x)$ for each $x \in \mathbb{R}^m$ and $H(t, x) = x$ for each $t \in I$ and for each x in some neighbourhood of 0.

In order to prove that r is a homotopy equivalence we will show that r induces an isomorphism between the homotopy groups.

(a) Consider a ss-map $S^i \rightarrow PL(0 \subset \mathbb{R}^m)$. This is nothing but an i -sphere of structures on an open neighbourhood U of 0, ie, a diagram:

$$\begin{array}{ccc} S^i \times U & \xrightarrow{\phi} & (S^i \times U)_\Theta \\ & \searrow \pi_1 & \swarrow p \\ & S^i & \end{array}$$

where Θ is a PL structure, p is a PL submersion and ϕ is a homeomorphism. Then the composed map

$$S^i \times \mathbb{R}^m \xrightarrow{f} S^i \times U \xrightarrow{\phi} (S^i \times U)_\Theta,$$

where $f(\tau, x) = (\tau, \rho(x))$, gives us a sphere of structures on the whole of \mathbb{R}^m . The germ of this structure is represented by ϕ . This proves that r induces an epimorphism between the homotopy groups.

(b) Let

$$f_0: S^i \times \mathbb{R}^m \rightarrow (S^i \times \mathbb{R}^m)_{\Theta_0}$$

and

$$f_1: S^i \times \mathbb{R}^m \rightarrow (S^i \times \mathbb{R}^m)_{\Theta_1}$$

be two spheres of structures on \mathbb{R}^m and assume that their germs in $S^i \times 0$ define homotopic maps of S^i in $PL(0 \subset \mathbb{R}^m)$. This implies that there exists a PL structure Θ and a homeomorphism

$$G: I \times S^i \times U \rightarrow (I \times S^i \times U)_\Theta$$

which represents a map of $I \times S^i$ in $PL(0 \subset \mathbb{R}^m)$ and which is such that

$$G(0, \tau, x) = f_0(\tau, x) \quad G(1, \tau, x) = f_1(\tau, x)$$

for $\tau \in S^i$, $x \in U$.

We can assume that $G(t, \tau, x)$ is independent of t for $0 \leq t \leq \varepsilon$ and $1 - \varepsilon \leq t \leq 1$. Also consider, in the topological manifold $I \times S^i \times \mathbb{R}^m$, the structure $\overline{\Theta}$ given by

$$\Theta_0 \times [0, \varepsilon) \cup \Theta \cup (1 - \varepsilon, 1] \times \Theta_1.$$

The three structures coincide since Θ restricts to Θ_i on the overlaps, and therefore $\bar{\Theta}$ is defined on a topological submanifold Q of $I \times S^i \times \mathbb{R}^m$.

Finally we define a homeomorphism

$$F: I \times S^i \times \mathbb{R}^m \rightarrow Q_{\bar{\Theta}}$$

with the formula

$$F(t, \tau, x) = \begin{cases} G(t, \tau, H(\frac{t}{\varepsilon}, x)) & 0 \leq t \leq \varepsilon \\ G(t, \tau, \rho(x)) & \varepsilon \leq t \leq 1 - \varepsilon \\ G(t, \tau, H(\frac{1-t}{\varepsilon}, x)) & 1 - \varepsilon \leq t \leq 1. \end{cases}$$

($x \in \mathbb{R}^m$). The map F is a homotopy of Θ_0 and Θ_1 , and then r induces a monomorphism between the homotopy groups which ends the proof of the proposition. \square

4.2 The following result states that a similar property applies to the structures on the tangent bundle \mathbb{R}^m .

Proposition *The restriction map*

$$r: \text{PL}(T\mathbb{R}^m) \rightarrow \text{PL}(T\mathbb{R}^m|0)$$

is a homotopy equivalence.

Proof We observe that $T\mathbb{R}^m$ is trivial and therefore we will write it as

$$\mathbb{R}^m \times X \xrightarrow{\pi_X} X$$

with zero-section $0 \times X$, where X is a copy of \mathbb{R}^m with the standard PL structure.

Given any neighbourhood U of 0 , let $H: I \times X \rightarrow X$ be the isotopy considered at the beginning of the proof of 4.1. We remember that a PL structure on $T\mathbb{R}^m$ is a PL structure of manifolds around the zero-section. Furthermore π_X is submersive with respect to this structure. The same applies for the PL structures on TU , where U is a neighbourhood of 0 in X . It is then clear that by using the isotopy H , or even only its final value $\rho: X \rightarrow U$, each PL structure on TU expands to a PL structure on the whole of $T\mathbb{R}^m$. The same thing happens for each sphere of structures on TU . This tells us that r induces an epimorphism between the homotopy groups. The injectivity is proved in a similar way, by using the whole isotopy H . It is not even necessary for H to be an isotopy, and in fact a homotopy would work just as well. \square

Summarising we can say that proposition 4.1 is established by expanding isotopically a typical neighbourhood of the origin to the whole of \mathbb{R}^m , while proposition 4.2 follows from the fact that 0 is a deformation retract of \mathbb{R}^m .

4.3 We will now prove that, still in \mathbb{R}^m , if we pass from the structures to their germs in 0, the differential becomes in fact an isomorphism of SS-sets (in particular a homotopy equivalence).

Proposition $d_0: \text{PL}(0 \subset \mathbb{R}^m) \rightarrow \text{PL}(T\mathbb{R}^m|0)$ is an isomorphism of complexes.

Proof As above, we write

$$T\mathbb{R}^m: \mathbb{R}^m \times X \xrightarrow{\pi_X} X \quad (X = \mathbb{R}^m)$$

and we observe that a germ of a structure in $T\mathbb{R}^m|0$ is locally a product in the following way. Given a PL structure Θ near U in $\mathbb{R}^m \times U$, where U is a neighbourhood of 0 in X , then, since π_X is a PL submersion, there exists a neighbourhood $V \subset U$ of 0 in X and a PL isomorphism between $\Theta|TV$ and $\Theta_V \times U$, where Θ_V is a PL structure on V , which defines an element of $\text{PL}(0 \subset \mathbb{R}^m)$. Since the differential $\underline{d} = d_0$ puts a PL structure around 0 in the fibre of $T\mathbb{R}^m$, then it is clear that d_0 is nothing but another way to view the same object. \square

4.4 The following theorem is the first important result we were aiming for. It states that the differential is a homotopy equivalence for $M = \mathbb{R}^m$.

In other words, the classification theorem 3.1 holds for $M = \mathbb{R}^m$.

Theorem $d: \text{PL}(\mathbb{R}^m) \rightarrow \text{PL}(T\mathbb{R}^m)$ is a homotopy equivalence.

Proof Consider the commutative diagram

$$\begin{array}{ccc} \text{PL}(\mathbb{R}^m) & \xrightarrow{d} & \text{PL}(T\mathbb{R}^m) \\ r \downarrow & & \downarrow r \\ \text{PL}(0 \subset \mathbb{R}^m) & \xrightarrow{d_0} & \text{PL}(T\mathbb{R}^m|0) \end{array}$$

By 4.1 and 4.2 the vertical restrictions are homotopy equivalences. Also by 4.3 d_0 is a homeomorphism and therefore d is a homotopy equivalence. \square

The two fundamental fibrations

4.5 The following results which prepare for the proof the classification theorem have a different tone. In a word, they establish that the majority of the restriction maps in the PL structure spaces are Kan fibrations.

Theorem For each compact pair $C_1 \subset C_2$ of M the natural restriction

$$r: \text{PL}(TM|C_2) \rightarrow \text{PL}(TM|C_1)$$

is a Kan fibration.

Proof We need to prove that each commutative diagram

$$\begin{array}{ccc} \Lambda^k & \longrightarrow & \text{PL}(TM|C_2) \\ \downarrow & & \downarrow r \\ \Delta^k & \longrightarrow & \text{PL}(TM|C_1) \end{array}$$

can be completed by a map

$$\Delta^k \rightarrow \text{PL}(TM|C_2)$$

which preserves commutativity.

In order to make the explanation easier we will assume $C_2 = M$ and we will write $C = C_1$. The general case is completely analogous, the only difference being that there are more “germs” (To those in C_1 we need to add those in C_2).

We will give details only for the lifting of paths when $(k = 1)$, the general case being identical.

We start with a simple observation. If ξ/X is a topological m -microbundle on the PL manifold X , if Θ is a PL structure on ξ and if $r: Y \rightarrow X$ is a PL map between PL manifolds, then Θ gives the induced bundle $r^*\xi$ a PL structure in a natural way using pullback. We will denote this structure by $r^*\Theta$. This has already been used (implicitly) to define the degeneracy operators $\Delta^{i+1} \rightarrow \Delta^i$ in $\text{PL}(\xi)$, in the particular case of elementary simplicial maps of 2.2.

Consider a path in $\text{PL}(TM|C)$, ie, a PL structure Θ' on $I \times TU = I \times (TM|U)$, with U an open neighbourhood of C . A lifting of the starting point of this path to $\text{PL}(TM)$ gives us a PL structure Θ'' on TM , such that $\Theta' \cup \Theta''$ is a PL structure Θ on the microbundle $0 \times TM \cup I \times TU$. Without asking for apologies we will ignore the inconsistency caused by the fact that the base of the last microbundle is not a PL manifold but a polyhedron given by the union of two PL manifolds along $0 \times U$. This inconsistency could be eliminated with some effort. We want to extend Θ to the whole of $I \times TM$. We choose a PL map $r: I \times M \rightarrow 0 \times M \cup I \times U$ which fixes $0 \times M$ and some neighbourhood of $I \times C$. Then $r^*\Theta$ is the required PL structure.

This ends the proof of the theorem. □

4.6 It is much more difficult to establish the property analogous to 4.5 for the PL structures on the manifold M , rather than on its tangent bundle:

Theorem For each compact pair $C_1 \subset C_2 \subset M^m$ the natural restriction

$$r: PL(C_2 \subset M) \rightarrow PL(C_1 \subset M)$$

is a Kan fibration, if $m \neq 4$.

Proof If we use cubes instead of simplices we need to prove that each commutative diagram

$$\begin{array}{ccc} I^k & \longrightarrow & PL(C_2 \subset M) \\ \downarrow & & \downarrow r \\ I^{k+1} & \longrightarrow & PL(C_1 \subset M) \end{array}$$

can be completed by a map

$$I^{k+1} \rightarrow PL(C_2 \subset M)$$

which preserves commutativity.

We will assume again that $C_2 = M$ and we will write $C_1 = C$.

We have a PL k -cube of PL structures on M and an extension to a $(k+1)$ -cube near C . This implies that we have a structure Θ on $I^k \times M$ and a structure Θ' on $I^{(k+1)} \times U$, where U is some open neighbourhood of C . By hypothesis the two structures coincide on the overlap, ie, $\Theta \upharpoonright I^k \times U = \Theta' \upharpoonright 0 \times I^k \times U$.

We want to extend $\Theta \cup \Theta'$ to a structure $\bar{\Theta}$ over the whole of $I^{k+1} \times M$, such that $\bar{\Theta}$ coincides with Θ' on $I^{k+1} \times$ some neighbourhood of C which is possibly smaller than U .

We will consider first the case $k = 0$, ie, the lifting of paths.

By the fibration theorem 1.8, if $m \neq 4$ there exists a sliced PL isomorphism over I

$$h: (I \times U)_{\Theta'} \rightarrow I \times U_{\Theta}$$

(recall that $\Theta' \upharpoonright 0 = \Theta$). There is the natural topological inclusion $j: I \times U \subset I \times M$ so that the composition

$$j \circ h: I \times U \rightarrow I \times M$$

gives a topological isotopy of U in M and thus also of W in M , where W is the interior of a compact neighbourhood of C in U . From the topological isotopy extension theorem we deduce that the isotopy of W in M given by $(j \circ h) \upharpoonright_W$

extends to an ambient topological isotopy $F: I \times M \rightarrow I \times M$. Now endow the range of F with the structure $I \times M_\Theta$.

Since it preserves projection to I , the map F provides a 1-simplex of $\text{PL}(M)$, ie a PL structure $\bar{\Theta}$ on $I \times M$. It is clear that $\bar{\Theta}$ coincides with Θ' at least on $I \times W$. In fact $F|_{I \times W}$ is the composition of PL maps

$$(I \times W)_{\Theta'} \subset (I \times U)_{\Theta'} \xrightarrow{h} I \times U_\Theta \subset I \times M_\Theta$$

and therefore is PL, which is the same as saying that $\bar{\Theta} = \Theta'$ on $I \times W$.

In the general case of two cubes (I^{k+1}, I^k) write X^* for $I^k \times X$ and apply the above argument to M^*, U^*, W^* . \square

4.7 The immersion theory machine

Notation We write $F(X)$, $G(X)$ for $\text{PL}(X \subset M)$ and $\text{PL}(TM|X)$ respectively.

We can now complete the proof of the classification theorem 4.1 under hypothesis (*).

Proof of 4.1 All the charts on M are intended to be PL homeomorphic images of \mathbb{R}^m and the simplicial complexes are intended to be PL embedded in some of those charts.

(1) *The theorem is true for each simplex A , linearly embedded in a chart of M .*

Proof We can suppose that $A \subset \mathbb{R}^m$ and observe that A has a base of neighbourhoods which are canonically PL isomorphic to \mathbb{R}^m . The result follows from 4.4 taking the direct limits.

More precisely, A is the intersection of a nested countable family $V_1 \supset V_2 \supset \dots \supset V_i \supset \dots$ of open neighbourhoods each of which is considered as a copy of \mathbb{R}^m . Then

$$F(A) = \varinjlim F(V_i) \quad G(A) = \varinjlim G(V_i) \quad d_A = \varinjlim d_{V_i}$$

Since each d_{V_i} is a weak homotopy equivalence by 4.4, then d_A is also a weak homotopy equivalence and hence a homotopy equivalence.

(2) *If the theorem is true for the compact sets $A, B, A \cap B$, then it is true for $A \cup B$.*

Proof We have a commutative diagram.

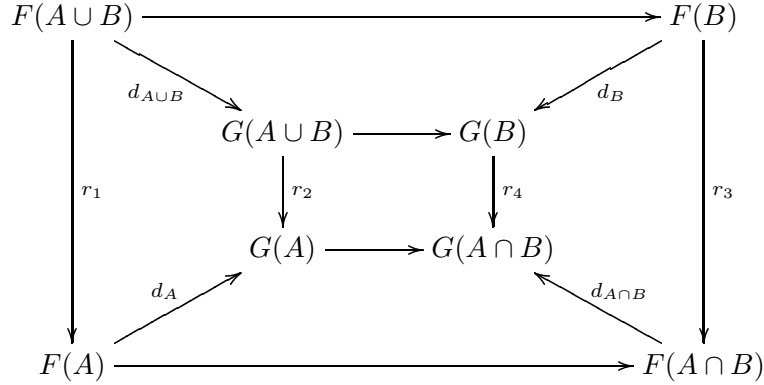

where the r_i are fibrations, by 4.5 and 4.6, and d_A , d_B , and $d_{A \cap B}$ are homotopy equivalences by hypothesis. It follows that d is a homotopy equivalence between each of the fibres of r_3 and the corresponding fibre of r_4 (by the Five Lemma). By 3.3.1 each of the squares is a pullback, therefore each fibre of r_1 is isomorphic to the corresponding fibre of r_3 and similarly for r_2, r_4 . Therefore d induces a homotopy equivalence between each fibre of r_1 and the corresponding fibre of r_2 . Since d_A is a homotopy equivalence, it follows from the Five Lemma that $d_{A \cup B}$ is a homotopy equivalence. In a word, we have done nothing but apply proposition II.1.7 several times.

(3) *The theorem is true for each simplicial complex (which is contained in a chart of M).* With this we are saying that if $K \subset \mathbb{R}^m$ is a simplicial complex, then

$$d_K: \text{PL}(K \subset \mathbb{R}^m) \rightarrow \text{PL}(T\mathbb{R}^m|K)$$

is a homotopy equivalence.

Proof This follows by induction on the number of simplices of K , using (1) and (2).

(4) *The theorem is true for each compact set C which is contained in a chart.* With this we are saying that if C is a compact set of \mathbb{R}^m , then

$$d_C: \text{PL}(C \subset \mathbb{R}^m) \rightarrow \text{PL}(T\mathbb{R}^m|C)$$

is a homotopy equivalence.

Proof C is certainly an intersection of finite simplicial complexes. Then the result follows using (3) and passing to the limit.

(5) *The theorem is true for any compact set $C \subset M$.*

Proof C can be decomposed into a finite union of compact sets, each of which is contained in a chart of M . The result follows applying (2) repeatedly.

(6) *The theorem is true for M .*

Proof M is the union of an ascending chain of compact sets $C_1 \subset C_2 \subset \dots$ with $C_i \subset \overset{\circ}{C}_{i+1}$.

From definitions we have

$$F(M) = \varprojlim F(C_i) \quad G(M) = \varprojlim G(C_i) \quad d_M = \varprojlim d_{C_i}$$

Each d_{C_i} is a weak homotopy equivalence by (5), hence d_M is a weak homotopy equivalence.

This concludes the proof of (6) and the theorem □

To extend theorem 3.1 to the case $m = 4$ we would need to prove that, if M is a PL manifold and none of whose components is compact, then the differential

$$d: \text{PL}(M) \rightarrow \text{PL}(TM)$$

is a homotopy equivalence without any restrictions on the dimension.

We will omit the proof of this result, which is established using similar techniques to those used for the case $m \neq 4$. For $m = 4$ one will need to use a weaker version of the fibration property 4.6 which forces the hypothesis of non-compactness (Gromov 1968).

However it is worth observing that in 4.4 we have already established the result in the particular case of $M^m = \mathbb{R}^m$ which is of importance. Therefore the classification theorem also holds for \mathbb{R}^4 , the Euclidean space which astounded mathematicians in the 1980's because of its unpredictable anomalies.

Finally, we must not forget that we still have to prove the classification theorem when M^m is a topological manifold upon which no PL structure has been fixed. We will do this in the next section.

The proof of the classification theorem gives us a stronger result: *if $C \subset M$ is closed, then*

$$d_C: \text{PL}(C \subset M) \rightarrow \text{PL}(TM|C) \tag{4.7.1}$$

is a homotopy equivalence.

Proof C is the intersection of a nested sequence $V_1 \supset \dots \supset V_i \supset$ of open neighbourhoods in M . Each d_{V_i} is a weak homotopy equivalence by the theorem applied with $M = V_i$. Taking direct limits we obtain that d_C is also a weak homotopy equivalence. □

Classification via sections

4.8 In order to make the result 4.6 usable and to arrive at a real structure theorem for $PL(M)$ we need to analyse the complex $PL(TM)$ in terms of classifying spaces. For this purpose we wish to finish the section by clarifying the notion of PL structure on a microbundle ξ/X .

As we saw in 2.2 when Θ defines a PL structure on ξ/X we do not need to require that $i: X \rightarrow U_\Theta$ is a PL map. When this happens, as in II.4.1, we say that a PL_μ -structure is fixed on ξ . In this case

$$X \xrightarrow{i} U_\Theta \xrightarrow{p} X$$

is a PL microbundle, which is topologically micro-isomorphic to ξ/X .

Alternatively, we can say that a PL_μ -structure on ξ is an equivalence class of topological micro-isomorphisms $f: \xi \rightarrow \eta$, where η/X is a PL microbundle and $f \sim f'$ if $f' = h \circ f$, and $h: \eta \rightarrow \eta'$ is a PL micro-isomorphism.

In II.4.1 we defined the ss-set $PL_\mu(\xi)$, whose typical k -simplex is an equivalence class of commutative diagrams

$$\begin{array}{ccc} \Delta^k \times \xi & \xrightarrow{f} & \eta \\ & \searrow & \swarrow \\ & \Delta^k & \end{array}$$

where f is a topological micro-isomorphism and η is a PL microbundle.

Clearly

$$PL_\mu(\xi) \subset PL(\xi).$$

Proposition *The inclusion $PL_\mu(\xi) \subset PL(\xi)$ is a homotopy equivalence.*

▼

Proof We will prove that

$$\pi_k(PL(\xi), PL_\mu(\xi)) = 0.$$

Let $k = 0$ and $\Theta \in PL(\xi)^{(0)}$. In the microbundle

$$I \times \xi: I \times X \xrightarrow{1 \times i} I \times E(\xi) \xrightarrow{p} I \times X$$

we approximate the zero-section $1 \times i$ using a zero-section j which is PL on $0 \times X$ (with respect to the PL structure $I \times \Theta$) and which is i on $1 \times X$.

This can be done by the simplicial ε -approximation theorem of Zeeman. This way we have a *new* topological microbundle ξ' on $I \times X$, whose zero-section is j . To this topological microbundle we can apply the homotopy theorem for

microbundles in order to obtain a topological micro-isomorphism $I \times \xi \xrightarrow{h} \xi'$. If we identify $I \times \xi$ with ξ' through h , we can say that the PL structure $I \times \Theta$ gives us a PL structure on ξ' . This structure coincides with Θ on $1 \times X$ and is, by construction, a PL_μ -structure on $0 \times X$. This proves that each PL structure can be connected to a PL_μ -structure using a path of PL structures.

An analogous reasoning establishes the theorem for the case $k > 0$ starting from a sphere of PL structures on ξ/X . □

▲

4.9 Let $\xi = TM$ and let

$$\begin{array}{ccc} TM & \xrightarrow{f} & \gamma_{\text{Top}}^m \\ \downarrow & & \downarrow \\ M & \xrightarrow{f} & B\text{Top} \end{array}$$

be a fixed classifying map. We will recall here some objects which have been defined previously. Let

$$\mathcal{B}: \text{Top}_m/PL_m \longrightarrow BPL_m \xrightarrow{p_m} B\text{Top}_m$$

be the fibration II.3.15; let

$$TM_f = f^*(\mathcal{B}) = TM[\text{Top}_m/PL_m]$$

be the bundle associated to TM with fibre Top_m/PL_m , and let

$$\text{Lift}(f)$$

be the space of the liftings of f to BPL_m .

Since there is a fixed PL structure on M , we can assume that f is precisely a map with values in BPL_m composed with p_m .

Classification theorem via sections *Assuming the hypothesis of theorem 3.1 we have homotopy equivalences*

$$PL(M) \simeq \text{Lift}(f) \simeq \text{Sect } TM[\text{Top}_m/PL_m].$$

Proof Apply 3.1, 4.8, II.4.1, II.4.1.1. □

The theorem above translates the problem of determining $PL(TM)$ to an obstruction theory with coefficients in the homotopy groups $\pi_k(\text{Top}_m/PL_m)$.

5 Classification of PL-structures on a topological manifold M . Relative versions

We will now abandon the hypothesis (*) of section 3, ie, we do not assume that there is a PL structure fixed on M and we look for a classification theorem for this general case. Choose a topological embedding of M in an open set N of an Euclidean space and a deformation retraction $r: N \rightarrow M \subset N$. Consider the induced microbundle r^*TM whose base is the PL manifold N . The reader is reminded that

$$r^*TM: N \xrightarrow{j} M \times N \xrightarrow{p_2} N$$

where p_2 is the projection and $j(y) = (r(y), y)$. Since N is PL, then the space $PL(r^*TM)$ is defined and it will allow us to introduce a *new differential*

$$d: PL(M) \rightarrow PL(r^*TM)$$

by setting $d\Theta := \Theta \times N$.

5.1 Classification theorem

$d: PL(M) \rightarrow PL(r^*TM)$ is a homotopy equivalence provided that $m \neq 4$.

The proof follows the same lines as that of Theorem 3.1, with some technical details added and is therefore omitted. □

5.2 Theorem Let $f: M \rightarrow B\text{Top}_m$ be a classifying map for TM . Then

$$PL(M) \simeq \text{Sect}(TM_f).$$

Proof Consider the following diagram of maps of microbundles

$$\begin{array}{ccccccc} TM & \xrightarrow{i} & r^*TM & \longrightarrow & TM & \xrightarrow{f} & \gamma_{\text{Top}}^m \\ \downarrow & & \downarrow & & \downarrow & & \downarrow \\ M & \xrightarrow{i} & N & \xrightarrow{r} & M & \xrightarrow{f} & B\text{Top}_m. \end{array}$$

Passing to the bundles induced by the fibration

$$\mathcal{B}: \text{Top}_m/\text{PL}_m \rightarrow B\text{PL}_m \rightarrow B\text{Top}_m$$

we have

$$PL(r^*TM) \simeq \text{Sect}((r^*TM)_{f \circ r}) \stackrel{i^*}{\simeq} \text{Sect}(TM_f). \quad \square$$

Therefore $PL(M)$ is homotopically equivalent to the space of sections of the Top_m/PL_m -bundle associated to TM .

It follows that in this case as well the problem is translated to an obstruction theory with coefficients in $\pi_k(Top_m/PL_m)$.

5.3 Relative version

Let M be a topological manifold with the usual hypothesis on the dimension, and let C be a closed set in M . Also let $PL(M \text{ rel } C)$ be the space of PL structures of M , which restrict to a given structure, Θ_0 , near C , and let $PL(TM \text{ rel } C)$ be defined analogously.

Theorem $d: PL(M \text{ rel } C) \rightarrow PL(TM \text{ rel } C)$ is a homotopy equivalence.

Proof Consider the commutative diagram

$$\begin{array}{ccc} PL(M) & \xrightarrow{d} & PL(M) \\ r_1 \downarrow & & \downarrow r_2 \\ PL(C \subset M) & \xrightarrow{d} & PL(TM|C) \end{array}$$

where we have written TM for r^*TM and $TM|C$ for $r^*TM|_{r^{-1}(C)}$; Θ_0 defines basepoints of both the spaces in the lower part of the diagram and r_1, r_2 are Kan fibrations. The complexes $PL(M \text{ rel } C)$, and $PL(TM \text{ rel } C)$ are the fibres of r_1 and r_2 respectively. The result follows from 4.7.1 and the Five lemma. \square

Corollary $PL(M \text{ rel } C)$ is homotopically equivalent to the space of those sections of the Top_m/PL_m - bundle associated to TM which coincide with a section near C (precisely the section corresponding to Θ_0). \square

5.4 Version for manifolds with boundary

The idea is to reduce to the case of manifolds without boundary. If M^m is a topological manifold with boundary ∂M , we attach to M an external open collar, thus obtaining

$$M_+ = M \cup_{\partial} \partial M \times [0, 1)$$

and we define $TM := TM_+|M$.

If ξ is a microbundle on M , we define $\xi \oplus \mathbb{R}^q$ (or even better $\xi \oplus \varepsilon^q$) as the microbundle with total space $E(\xi) \times \mathbb{R}^q$ and projection

$$E(\xi) \times \mathbb{R}^q \rightarrow E(\xi) \xrightarrow{p_\xi} M.$$

This is, obviously, a particular case of the notion of direct sum of locally trivial microbundles which the reader can formulate.

Once a collar $(-\infty, 0] \times \partial M \subset M$ is fixed we have a canonical isomorphism

$$TM_+|_{\partial M} \approx T(\partial M) \oplus \mathbb{R} \tag{5.4.1}$$

and we *require* that a PL structure on TM is always so that it can be desuspended according to (5.4.1) on the boundary ∂M . We can then define a *differential*

$$d: \text{PL}(M) \rightarrow \text{PL}(TM)$$

and we have:

Theorem *If $m \neq 4, 5$, then d is a homotopy equivalence .*

Proof (Hint) Consider the diagram of fibrations

$$\begin{array}{ccc}
 \text{PL}(M_+ \text{rel } \partial M \times [0, 1)) & \xrightarrow{d} & \text{PL}(TM_+ \text{rel } \partial M \times [0, 1)) \\
 \downarrow & & \downarrow \\
 \text{PL}(M) & \xrightarrow{d} & \text{PL}(TM) \\
 \downarrow r_1 & & \downarrow r_2 \\
 \text{PL}(TM) & \xrightarrow{d} & \text{PL}(T\partial M)
 \end{array}$$

The reader can verify that the restrictions r_1, r_2 exist and are Kan fibrations whose fibres are homotopically equivalent to the upper spaces and that d is a morphism of fibrations. The differential at the bottom is a homotopy equivalence as we have seen in the case of manifolds without boundary, the one at the top is a homotopy equivalence by the relative version 5.3 Therefore the result follows from the Five lemma. □

5.5 The version for manifolds with boundary can be combined with the relative version. In at least one case, the most used one, this admits a good interpretation in terms of sections.

Theorem *If $\partial M \subset C$ and $m \neq 4$, (giving the symbols the obvious meanings) then there is a homotopy equivalence:*

$$\text{PL}(M \text{rel } C) \simeq \text{Sect}(TM_f \text{rel } C)$$

where $f: M \rightarrow B\text{Top}_m$ is a classifying map which extends such a map already defined near C . □

Note If $\partial M \not\subset C$, then $\text{Sect}(TM_f)$ has to be substituted by a more complicated complex, which takes into account the sections on ∂M with values in $\text{Top}_{m-1}/\text{PL}_{m-1}$. However it can be proved, *in a non trivial way*, that, if $m \geq 6$, then there is an equivalence analogous to that expressed by the theorem.

Corollary *If M is parallelizable, then M admits a PL structure.*

Proof $(TM_+)_f$ is trivial and therefore there is a section. □

Proposition *Each closed compact topological manifold has the same homotopy type of a finite CW complex.*

Proof [Hirsch 1966] established that, if we embed M in a big Euclidean space \mathbb{R}^N , then M admits a normal disk bundle E .

E is a compact manifold, which has the homotopy type of M and whose tangent microbundle is trivial. Therefore the result follows from the Corollary. □

5.6 We now have to tackle the most difficult part, ie, the calculation of the coefficients $\pi_k(\text{Top}_m/\text{PL}_m)$ of the obstructions. For this purpose we need to recall some important results of the immersion theory and this will be done in the next part.

Meanwhile we observe that, since

$$\text{PL}_m \subset \text{Top}_m \rightarrow \text{Top}_m/\text{PL}_m$$

is a Kan fibration, we have:

$$\pi_k(\text{Top}_m/\text{PL}_m) \approx \pi_k(\text{Top}_m, \text{PL}_m).$$

Bibliography

Note: *page numbers are temporary*

- J.W. ALEXANDER, “An example of a simply connected surface bounding a surface which is not simply connected”, *Proc. Nat. Acad. Sci. U.S.A.* **10** (1924), pp. 8–10.
- J.W. ALEXANDER, “On the deformation of an n -cell”, *Proc. Nat. Acad. Sci. U.S.A.* **9** (1923), pp.406–407.
- J.W. ALEXANDER, “On the subdivision of 3-spaces by a polyhedron”, *Proc. Nat. Acad. Sci. U.S.A.* **10** (1924), pp. 6–8.
- J.W. ALEXANDER, “The combinatorial theory of complexes”, *Ann. Math.* **31** (1930), pp.292–320.
- P. ALEXANDROFF, H. HOPF, *Topologie*, Springer–Verlag 1935.
- L. ANTOINE, “Sur la possibilité d’étendre l’homéomorphie de deux figures à leur voisinage”, *C.R. Acad. Sci. Paris* **171** (1920), pp. 661–663.
- M.A. ARMSTRONG, G.E. COOKE, C.P. ROURKE, Princeton notes on the hauptvermutung (1968), WarwickUniv. (Coventry).
- M. ATIYAH, “Bordism and cobordism”, *Proc. Cam. Phil. Soc.* **57** (1961) pp. 200–208.
- N.A. BAAS, “On bordism theory of manifolds with singularities”, *Math. Scand.* **33** (1973), pp. 279–308.
- D. BARDEN, “The sructure of manifolds”, *Doctoral thesis*, Cambridge (1963).
- M.G. BARRATT, V.K.A.M. GUGENHEIM, J.C. MOORE, “On semisimplicial fibre bundles”, *Am. J. Math.* **81** (1959), pp. 639–657.
- R.H. BING, Radial Engulfing, Conference on Topology of Manifolds, Michigan State University 1967

- M. BROWDER, “Structures on $M \times \mathbb{R}$ ”, *Proc. Camb. Phil. Soc.* **61** (1965), pp. 337–345.
- M. BROWDER, *Surgery on simply-connected manifolds*, Springer 1972.
- E. BROWN JR, *Cohomology theories*, *Annals of Math* 75 (1962), pp. 467–484
- M. BROWN, “A proof of the generalized Schoenflies theorem”, *Bull. Amer. Math. Soc.* **66** (1960), pp. 74–76.
- M. BROWN, H. GLUCK, “Stable structures on manifolds”, *Ann of Math.* (1964), pp. 1–58.
- S. BUONCRISTIANO, C.P. ROURKE, B.J. SANDERSON, “A Geometric Approach to Homology Theory”, *L.M.S. Lecture Note Series* **18** (1976), C.U.P.
- S.S. CAIRNS, “The manifold smoothing problem”, *Bull. Amer. Math. Soc.* **67** (1961), pp. 237–238.
- A.J. CASSON, D.P. SULLIVAN, M.A. ARMSTRANG, C.P. ROURKE, G.E. COOKE, *The Hauptvermutung Book*, *K-monographs in Mathematics* 1996.
- J. CERF, “Isotopie et pseudo-isotopie”, *Proc. Int. Congr. Math.*, Moscow (1966), pp. 429–437.
- J. CERF, “La nullité du groupe Γ_4 ”, *Sem. H. Cartan*, Paris 1962–63, n. 8, 9, 10, 20, 21.
- J. CERF, “Sur les difféomorphismes de la sphère de dimension trois ($\Gamma_4 = 0$)”, *Springer Lecture Notes in Math.* **53** (1968).
- A.V. CERNAVSKII, “Local contractibility of the homeomorphism group of a manifold”, (Russian) *Math. Sbornik*, vol. 79 (121) 1969, pp. 307–356; English version *Math. U.S.S.R. Sbornik* **8** (1969), No. 3, pp. 287–333.
- A.V. CERNAVSKII, “Local contractibility of the homeomorphism group of a manifold”, *Soviet Math. Doklady* **9** (1968), pp. 1171–1174; *Dokl. Akad. Nauk. SSSR*, Tom 182 (1968), No. 3, pp. 510–513.
- T.A. CHAPMAN, “Topological invariance of Whitehead torsion”, *Amer. J. Math.* **96** (1974), pp. 488–497.
- E. CONNELL, “Approximating stable homeomorphisms by piecewise linear ones”, *Ann. of Math.* **78** (1963), pp. 326–338.

- E. CONNELL, “A topological H -cobordism theorem for $n > 5$ ”, *Illinois J. Math.* 11(1967), pp.300-309
- P. CONNER, E. FLOYD, “The relation of cobordism to K -theories”, *Springer L.N. in Math.* **28**(1966).
- P. CONNER, E. FLOYD, “Torsion in SU -bordism”, *Mem. Amer. Math. Soc.* **60** (1966).
- P. CONNER, E. FLOYD, *Differentiable periodic maps*, Springer 1964.
- P. DEDECKER, “Variétés linéaires par morceaux et variétés combinatoires”, *Annali di Mat.Pura Appl.* Serie 4, t. 60 (1962), pp. 365–383.
- R.D. EDWARDS, R.C. KIRBY, “Deformations of spaces of imbeddings”, *Ann. of Math.* **93**(1971), pp. 63–88.
- S. EILENBERG, N. STEENROD, *Foundations of Algebraic Topology*, Princeton Univ. Press, 1952.
- S. EILENBERG, S. MACLANE, “On the groups $H(\pi, n)$ ”, *Ann. of Math.* **58** (1953), pp. 55-106, **60** (1954), 49–139 and 513–557.
- D. B. GAULD, “The canonical Schoenflies theorem”, *Proc. Amer. Math. Soc.* **27** (1971), pp. 603–612
- J. MILNOR, “On the cobordism ring Ω^* and a complex analogue”, Part I, *Amer. J. Math.* **82** (1960), pp. 505–521.
- L.C. GLASER, “Geometrical Combinatorial Topology, I and II”, *Van Nostrand Math. Studies*, **27**, **28** (1970).
- M.L. GROMOV, “Stable mappings of foliations into manifolds”, *Izv. Akad. Nauk. SSSR Mat.* **33** (1969), pp. 707–734; *Transl. Math. USSR (Izvestia)* **3** (1969), pp. 671–693.
- V. GUGENHEIM, *Semisimplicial Homotopy Theory*, MAA Studies in Mathematics Vol. 5: Studies in Modern Topology, P.J. Hilton Editor (1968).
- A. HAEFLIGER, “Knotted $4k - 1$ -spheres in $6k$ -space”, *Ann. of Math.* **75** (1962), pp. 452–466.
- A. HAEFLIGER, “Knotted spheres and related geometric problems”, *Proc. ICM, Moscow* (1966), pp.337–345.

- A. HAEFLIGER, V. POENARU, “Classification des immersions combinatoires”, *Publ. Math. IHES* **23** (1964), pp. 75–91.
- A. HELLER, “Homotopy resolutions of semi-simplicial complexes”, *Trans. A.M.S.* **80** (1955), pp. 299–344.
- M. HIRSCH, “On normal microbundles”, *Topology* **5** (1966), pp. 229–240.
- M. HIRSCH, B. MAZUR, “Smoothings of piecewise-linear manifolds”, *Annals of Math. Studies* **80** Princeton Univ. Press, 1974.
- M.W. HIRSCH, “Immersion of manifolds”, *Trans. Amer. Math. Soc.* **93** pp. 242–276 (1959).
- W.C. HSIANG, J.L. SHANESON, “Fake tori, the annulus conjecture and the conjectures of Kirby”, *Proc. Nat. Acad. Sci. U.S.A.* **62** (1969), pp. 687–691.
- J.F. HUDSON, E.C. ZEEMAN, “On combinatorial isotopy”, *Publ. I.H.E.S.* **19** (1964), pp. 69–74.
- J.F.P. HUDSON, “Extending piecewise-linear isotopies”, *Proc. London Math. Soc.* **16** (1966), pp. 651–668.
- J.F.P. HUDSON, “On transversality”, *Proc. Camb. Phil. Soc.* **66** (1969), pp. 17–20.
- J.F.P. HUDSON, *Piecewise-linear topology*, Benjamin Inc., New York, 1969.
- W. HUEBSCH, M. MORSE, “The dependence of the Schoenflies extension on an accessory parameter”, *J. Analyse Math.* **8** (1960–1961), pp. 209–222.
- D. HUSEMOLLER, *Fiber Bundles*, Springer-Verlag 1994.
- M.C. IRWIN, “Embeddings of polyhedral manifolds”, *Ann. of Math.* **82** (1965), pp. 1–14.
- D.M. KAN, “Abstract Homotopy I. II”, *Proc. Nat. Acad. Sci. Usa* **41** (1955), pp. 1092–1096.
- M. KATO, “Topological Resolution of Singularities”, *Topology* **12** (1973) pp. 355–372.
- M. KERVAIRE, J. MILNOR, “Groups of homotopy spheres”, I, *Ann. of Math.* **77** (1963), pp. 504–537.

- M.A. KERVAIRE, “A manifold which does not admit any differentiable structure”, *Comm. Math.Helv.* **34** (1960), pp. 257–270.
- R.C. KIRBY, L.C. SIEBENMANN, “On the triangulation of manifolds and the Hauptvermutung”, *Bull.Amer. Math. Soc.* **75** (1969), pp. 742–749.
- R.C. KIRBY, L.C. SIEBENMANN, “Remarks on topological manifolds”, *Notices Amer. Math. Soc.* **16** (1969), p. 698 e p. 848.
- R.C. KIRBY, L.C. SIEBENMANN, “Some theorems on topological manifolds”, in *Manifolds, SpringerNotes* **97** (1971).
- R.C. KIRBY, L.C. SIEBENMANN, “Foundational Essays on Topological Manifolds, Smoothings and Triangulations”, *Ann. of Math. Studies* **88** (1977).
- R.C. KIRBY, “Stable homeomorphisms and the annulus conjecture”, *Ann. of Math.* **89** (1969), pp. 575–582.
- R.C. KIRBY, *Lectures on triangulation of manifolds*, Mimeo, Univ. of Calif. at Los Angeles, 1969.
- R. KIRBY, “4-manifolds problems” in: Four-manifold theory, *Contemp. Math.* **35** (1984), pp. 513–528
- R. KIRBY, “The Topology of 4-Manifolds”, *Lecture Notes in Mathematics* no. 1374 (1989)
- J.M. KISTER, “Microbundles are fiber bundles”, *Ann. of Math.* **80** (1964), pp. 190–199.
- N.H. KUIPER, R.K. LASHOF, “Microbundles and bundles, I,”, *Invent. Math.* **1** (1966), pp.1–17.
- N.H. KUIPER, R.K. LASHOF, “Microbundles and bundles, II,”, *Invent. Math.* **1** (1966), pp.243–259.
- R. LASHOF, M. ROTHENBERG, “Microbundles and smoothing”, *Topology* **3** (1965), pp.357–388.
- R. LASHOF, “The immersion approach to triangulations”, *Proc. of Symposia in Pure Mathematics* Vol. XXII (1971), pp. 131–164.
- J.A. LEES, “Immersions and surgeries of topological manifolds”, *Bull. Amer. Math. Soc.* **75**(1969), pp. 529–534.

- S. MACLANE, “Constructions simpliciales acycliques”, *Colloque Henri Poincaré*, Paris, 1954.
- J.P. MAY, “Simplicial objects in algebraic topology”, *Van Nostrand Math. Studies* **11**(1967).
- B. MAZUR, “Differential topology from the viewpoint of simple homotopy theory”, *Publ.I.H.E.S.* **15** (1963), pp. 5–93
- J. MILNOR, “Microbundles, Part I”, *Topology*, Vol. 3 (1964), supplement 1, pp. 53–80.
- J. MILNOR, *Lectures on the h-cobordism theorem*, Princeton Mathematical Notes, 1965.
- J. MILNOR, *Topology from the differentiable viewpoint*, Virginia 1965.
- J. MILNOR, *Microbundles and differentiable structures*, mimeographed, Princeton Univ., September 1961.
- J.W. MILNOR, “Two complexes which are homeomorphic but combinatorially distinct”, *Ann. of Math.* **74** (1961), pp. 575–590.
- J. MILNOR, J. STASHEFF, “Lectures on characteristic classes”, *Ann. of Math. Studies* **76** (1974).
- E. MOISE, “Affine structures on 3-manifolds”, *Ann. of Math.* **56** (1952), pp. 96–114.
- E.E. MOISE, *Geometric topology in dimensions 2 and 3*, Springer-Verlag 1977.
- J. MOORE, “Semisimplicial complexes and Postnikov systems, Sym. Int. Top. Alg. Mexico (1958), pp.232–247.
- J. MORGAN, D. SULLIVAN, “Transversality characteristic class and linking cycles in surgery theory”, *Ann. of Math.* **99** (1974), pp. 463–544.
- C. MORLET, “Hauptvermutung et triangulation des variétés”, Sémin. Bourbaki 1968–69, Exposé n.362.
- C. MORLET, “Microfibrés et structures différentiables”, Sémin. Bourbaki (1963), Exposé n. 263.
- C. MORLET, *Plongements et automorphismes des variétés*, (notes multigraphiées), Cours Peccot, Collège de France, Paris 1969.

- J. MUNKRES, “Differentiable isotopies on the 2–sphere”, *Mich. Math. J.* **7** (1960), pp.193–197.
- J. MUNKRES, “Elementary differential topology”, *Ann. of Math. Study* **54** (1961), Princeton Univ. Press.
- J. MUNKRES, “Obstructions to smoothing piecewise differentiable homeomorphisms”, *Ann. of Math.* **72** (1960), pp. 521–544 .
- M.H.A. NEWMAN, “On the foundations of combinatorial analysis situs”, *Proc. Acad. Sci. Amsterdam* **29** (1926), pp. 611–641.
- M.H.A. NEWMAN, “The engulfing theorem for topological manifolds”, *Ann. of Math.* **84**(1966), pp. 555–571.
- S.P. NOVIKOV, “The methods of algebraic topology from the viewpoint of cobordism theory”, *Math. USSR–Izv* (1967), pp. 827–913.
- S.P. NOVIKOV, “Topological invariance of rational Pontrjagin classes”, *Doklady* **163** (1965), pp.298–300 (*Soviet Math.* (1965), pp. 921–923).
- R. PALAIS, “Extending diffeomorphisms”, *Proc. Amer. Math. Soc.* **11** (1960), pp. 274–277.
- L.S. PONTRJAGIN, “Harakterisiceskie cikly differenciruemyh mnogoobarzij”, *Mat. Sb.* **21** (63)(1947), pp. 233–284.
- D.G. QUILLEN, “The geometrical realization of a Kan fibration is a Serre fibration”, *Proc. Amer. Math. Soc.* **19** (1968), pp. 1499–1500.
- V.A. ROHLIN, “A 3–dimensionl manifold is the boundary of a 4–dimensional manifold” (Russian), *Doklady Akad. Nauk. S.S.S.R.* **81** (1951), p. 355.
- D. ROLFSEN, *Knots and links*, Publish or Perish, 1976.
- C. ROURKE, *The Structure of Manifolds*, mimeographed
- C.P. ROURKE, B.J. SANDERSON, “ Δ –sets I, II”, *Q.J. Math.*, Oxford Ser. 2, **22** (1971), pp. 321–338 and pp. 465–485.
- C.P. ROURKE, B.J. SANDERSON, “Block–bundles I, II, III”, *Ann. of Math.* **87**, (1968).
- C.P. ROURKE, B.J. SANDERSON, “Introduction to Piecewise–linear Topology”, *Ergebnisse Math.*, Band 69, Springer–Verlag 1972.

- C.P. ROURKE, B.J. SANDERSON, “On topological neighborhoods”, *Compositio Math.* **22** (1970), pp.387–424.
- C.P. ROURKE, *On conjectures of Smale and others concerning the diffeomorphism group of S^n* , Mimeo, Univ. of Warwick 1972.
- C.P. ROURKE, *On structure theorems*, Mimeo, Univ. of Warwick 1972.
- T.B. RUSHING, *Topological Embeddings*, Academic Press, 1973.
- B.J. SANDERSON, “The simplicial extension theorem”, *Proc. Camb. Phil. Soc.* **77** (1975), pp.497–498.
- L.C. SIEBENMANN, “Deformation of homeomorphisms on stratified sets”, *Comment. Math. Helv.* **47** (1972), pp. 123–163.
- L.C. SIEBENMANN, “Topological manifolds”, *Proc. I.C.M. Nice* (1970).
- S. SMALE, “Diffeomorphisms of the 2–sphere”, *Proc. Amer. Math. Soc.* **10** (1959), pp.621–626.
- S. SMALE, “Generalised Poincaré’s conjecture in dimensions > 4 ”, *Ann. of Math.* **74** (1961)pp. 391–466.
- S. SMALE, “On structure of manifolds”, *Amer. J. of Math.* **84** (1962), pp. 387–399.
- S. SMALE, “The classification of immersion of spheres in euclidean space”, *Ann. of Math.* **69**pp. 327–344 (1959).
- E.H. SPANIER, *Algebraic Topology*, McGraw–Hill 1966.
- J. STALLINGS, “Infinite processes”, pp. 245–253 in *Differential and Combinatorial Topology*, ed. S.Cairns, Princeton Univ. Press 1965.
- J. STALLINGS, “Polyhedral homotopy spheres”, *Bull. Amer. Math. Soc.* **66** (1960), pp. 485–488.
- J. STALLINGS, *Lectures on polyhedral Topology*, Bombay 1967.
- J. STALLINGS, “Notes on polyhedral topology”, *Tata Institute* (1967)
- J. STALLINGS, “The p.l. structure of euclidean space”, *Proc. Cambridge Philos. Soc.* **58**, (1962), pp. 481–488.
- J. STALLINGS, “Whitehead torsion of free products”, *Ann. of Math.* **88**, (1965),pp. 354–363.

- N. STEENROD, *The Topology of Fibre Bundles*, Princeton 1951.
- R.E. STONG, *Notes on cobordism theory*, Princeton Univ. Press. (1968).
- D. SULLIVAN, “Geometric Topology, Part I”, Mimeographed notes, MIT 1970.
- D. SULLIVAN, “Singularities in Spaces”, Proc. of Liverpool Singularities Symposium II, *Lecture Notes in Math.* **209** (1971), pp. 196–206.
- D.P. SULLIVAN, “On the hauptvermutung for manifolds”, *Bull. Amer. Math. Soc.* **73** (1967), pp.598–600.
- D.P. SULLIVAN, *Triangulating homotopy equivalences*, Doctorial thesis, Princeton Univ. (1966).
- R.M. SWITZER, *Algebraic Topology—Homotopy and Homology*, Springer.
- R. THOM, “Des variétés combinatoires aux variétés différentiables”, *Proc. I.C.M.* 1958, C.U.P.1960.
- R. THOM, “La classification des immersion d’après Smale”, *Seminaire Bourbaki*, décembre1957.
- C.T.C WALL, “Determination of the cobordism ring”, *Ann. of Math.* **72** (1960), pp. 292–311.
- C.T.C WALL, “Homeomorphism and diffeomorphism classification of manifolds”, *Proc. I.C.M.*,Moscow 1966, pp. 450–459.
- C.T.C WALL, “On homotopy tori and the annulus theorem”, *Bull. London Math. Soc.*, **1** (1969),pp. 95–97.
- C.T.C WALL, *Surgery on Compact Manifolds*, Academic Press 1971.
- J.H.C. WHITEHEAD, “On C^1 complexes”, *Ann. of Math.* **41** (1940), pp. 804–824.
- J.H.C. WHITEHEAD, “Simplicial spaces nuclei and m -groups”, *Proc. London Math. Soc.* **45** (1939).
- J.H.C. WHITEHEAD, “Combinatorial homotopy I”, *B.A.M.S.* **55** (1949), pp. 213–245.
- H. WHITNEY, “Analytic extension of differentiable functions defined on closed sets”, *Trans. Amer.Math. Soc.* **36** (1934), pp. 63–89.

- H. WHITNEY, “The self-intersections of a smooth n -manifold in $2n$ -space”, *Ann. of Math.* **45** (1944), pp. 220–246.
- E.C. ZEEMAN, “Relative simplicial approximation”, *Proc. Camb. Phil. Soc.* **60** (1964), 39–43.
- E.C. ZEEMAN, “Seminar on combinatorial topology”, *Notes I.H.E.S. and Warwick*, (1963).
- E.C. ZEEMAN, “The generalised Poincaré conjecture”, *B.A.M.S.* **67** (1961) p. 270.
- E.C. ZEEMAN, *The Poincaré conjecture for $n \geq 5$. Topology of 3-manifolds and related topics*, M.K. Fort (Ed.), Prentice Hall 1962.
- E.C. ZEEMAN, *Letter to Colin Rourke*, 1966.